



0426

CARDIOLINE®

**DELTA 60 Plus**

PORTABLE 6 CHANNEL ELECTROCARDIOGRAPH

UPGRADABLE VERSION

**SERVICE MANUAL**

**REMCO ITALIA S.p.A.**

S. Pedrino di Vignate ( MI ) ITALY

Tel. +39(0) 2-950518.1 - Fax +39(0) 2-9566013

# Index

<b>1. ACKNOWLEDGEMENT</b>	<b>3</b>
<b>2. GENERAL DESCRIPTIONS.</b>	<b>4</b>
<b>2.1 Connections to external equipments</b>	<b>5</b>
2.1.1 ECG signal output.	6
2.1.2 ECG signal input.	6
2.1.3 RS 232-C bi-directional gate	6
2.1.4 Auxiliary output	6
<b>2.2 Check up of safety features</b>	<b>7</b>
2.2.1 Instrumentation	7
2.2.2 Test of the supplied voltage	7
2.2.3 Ground point test	7
2.2.4 Leakage currents test	7
<b>2.3 Technical features check up</b>	<b>8</b>
2.3.1 Instrumentation	8
2.3.2 Sensitivity and internal mV test	8
2.3.3 Paper speed test	8
2.3.4 Frequency response test	8
<b>2.4 Open the equipment and get to the internal parts.</b>	<b>9</b>
2.4.1 How to open the equipment	9
2.4.2 Disconnecting the analog board (5802200+5802201)	9
2.4.3 Disassembling the CU board (5802203+5802204)	9
2.4.4 Disassembling the PW/printer board (5802205 or <b>5802210 x rel. <math>\geq 3.00</math></b> )	9
2.4.5 Disassembly the RSAIO board (5802198)	9
2.4.6 Disassembling the printer group (2820057)	9
2.4.7 Disassembling the battery (7741715)	9
2.4.8 Disassembling the UPU peripheral board (5802208)	9
<b>3. CIRCUITRY</b>	<b>10</b>
<b>3.1 Analog boards (5802200+ 5802201)</b>	<b>10</b>
3.1.1 Functional description	10
3.1.2 ANLG Connections	11
<b>3.2 CU board (5802203)</b>	<b>13</b>
3.2.1 Functional description	13
3.2.2 CU connections	13
<b>3.3 MEM board (5802204)</b>	<b>15</b>
3.3.1 Functional description	15

3.3.2 MEM Connections	16
<b>3.4 User Peripheral Board UPU (5802208)</b>	<b>17</b>
3.4.1 Functional description	17
3.4.2 UPU Connections	17
<b>3.5 Power Supply/Print. Board PSPT (5802205 or 5802210 x rel. <math>\geq</math> 3.00)</b>	<b>19</b>
3.5.1 Functional description	19
3.5.2 PSPT connections	19
<b>3.6 I/O board -RSAIO- (5802198)</b>	<b>22</b>
3.6.1 RSAIO connections	22
<b>4. SETUP</b>	<b>23</b>
4.1 HW Setup	23
4.2 FW "Service setup procedure"	25
<b>5. TROUBLESHOOTING PROCEDURES</b>	<b>26</b>
5.1 Error Codes	28
<b>6. TECHNICAL FEATURES</b>	<b>29</b>
<b>7. SPARE PARTS LIST</b>	<b>30</b>
<b>8. ELECTRIC AND ASSEMBLING DIAGRAMS</b>	<b>31</b>

# 1. Acknowledgement

Delta 60 plus UPgradable Version is a portable 6 channels ECG recording machine with universal supply type; it's available also in interpretative, calculation parameter and stress test version (for more information see user manual). It can be powered whether by the A.C. as by rechargeable accumulators. Delta 60 plus UPgradable Version automatically switches the supply source during the operation.

The voltages are  $230\text{ V} \pm 10\%$  and  $115\text{ V} \pm 10\%$ . These options can be selected on factory by properly connecting the cables of the supply transformer.

The rechargeable accumulators allow 1 hour of continuous printing.

Safety features:

Class I, type CF in accordance to the standard IEC 601-1 (CEI 62-5) and IEC 601-2-25 (CEI 62-76).

REMCO ITALIA S.p.A. is responsible of the equipments made by itself in terms of safety, reliability and functionality only if:

- Maintenance, service and eventual modifications are made by authorised and trained personnel by REMCO ITALIA S.p.A.
- The electric system which Delta 60 plus UPgradable Version is connected with, is in accordance to the standard CEI.
- Delta 60 plus UPgradable Version is used as per the User Manual

## Special notices

- IF THE MAINS SYSTEM OR THE POWER SUPPLY CABLE ARE IN POOR CONDITIONS, USE THE EQUIPMENT ONLY ON BATTERY.
- If the electrocardiograph remains unused for long period is necessary to take out the battery pack before: for this operation please contact the nearest Cardioline Service Point.
- If a leak of fluid is noted from the battery, please take care the fluid does not pollute the external environment. Please contact the nearest Cardioline Service Point.
- **Equipotentiality**  
For using the connection dispositive between the equipment and the equipotentiality network please read the instructions coming with the equipotentiality plug. For any connection to other equipment, please consult the nearest Cardioline Service Point.
- **Cleaning and Sterilization**  
For cleaning and disinfecting of the equipment's surface it may be used the sterilizant detergent solution generally used in hospitals, with low alcohol content. The unit's surface may be cleaned with a wet tissue, and the liquid must never infiltrate inside the equipment ! Wash the electrodes with water and/or use only cool sterilization.
- **Transport**  
For transporting the equipment, please use the original packing. The equipment should be always handled with care and preserved from vibrations, heat sources, fluids and whatever else might damage it.
- **Dischagement**  
Batteries must be treated according to the current rules about Special Waste. No other part of the equipment must be considered Special Waste.

Any other information can be requested directly to:

REMCO ITALIA S.p.A.  
Service Department  
Strada Rivoltana Nuova, 53  
20060 S. Pedrino di Vignate (MI) ITALY  
Tel.: +39-2-95.05.18.1  
Fax: +39-2-95.66.013

## 2. General Descriptions

Delta 60 plus UPgradable version is an electrocardiograph with simultaneous acquisition of the 12 standard leads. The user can operate through a touch keyboard with 13 dedicated buttons and 47 alphanumeric keys, an alphanumeric LCD display, 2 rows X 16 columns, and a piezoelectric buzzer.

The output document is made on thermal paper 210 mm. with vertical resolution of 8 dot/mm. and the horizontal one of 20 dot/mm. at the speeds of 6.25, 12.5 and 25 mm/sec. and of 10 dot/mm at the speed of 50 mm/sec.

Delta 60 plus UPgradable version is based on a microprocessor Intel 80C196KC which controls all the functions and is composed by 5 groups of boards:

- Central unit CU (cod.5802203+5802204)  
it holds two microprocessors, the RAM memory, the EPROM memory or Flash Eprom, the decoder logic of the addresses and some service devices.
- User peripheral unit UPU (cod.5802208)  
it holds the decoder circuit of the keyboard, the display, the buzzer controller, the clock/RAM for the setup and the necessary logic.
- Analog ANLG (cod.5802200-5802201)  
it is made by two sections: the first one is isolated and is in contact to the patient and the second one is an interface with the CU board.
- Analog I/O-RS 232 AIORS (cod.5802198)  
it is made by three sections dedicated to the analog output, the analog input and to the serial port RS 232.
- Power supply PSPT (cod.5802205 or **5802210 x rel.  $\geq 3.00$** )  
there is the power supply and the control circuits of the thermal printer.

The CU (5802203+5802204) has a primary role (see general block diagram) managing the principal functions which are summarized here below:

- The analog unit elaborates and amplifies the ECG signal at the patient cable electrodes and takes the channels from 9 to 8:V1÷V6,D1,D2. These 8 channels are sequentially carried to a single line through a multiplexer. This last has 3 decoding lines which are controlled by CU.

The analog unit informs the CU about eventual saturation on the chest leads and/or on the peripheral ones and receives from CU the command (INST) and the power supply.

The central unit acquires in cyclical permutation the 8 channels and rebuilds the derivations D1, D2, D3, aVR, aVL, aVF.

The analog signal processing of the 12 channels keeps then on with high-pass filtering algorithms, low-pass and "pseudo" notch calculation, and the heart rate.

- The UPU holds several devices which are read or written by CU:
  - Keyboard: the CU identifies the pressed button by the special scanner.
  - Clock/RAM setup: the CU reads date and time when needed and modifies them on the user's request. It uses also the part of RAM setup in order to store all the useful parameters for the proper system operations. It reads them when needs and up-to-date them anytime that the user decided to modify them.
  - Buzzer: the CU can produce a beep variable in the time through the special interface. For example it can produce the feedback short click when pressing a button and the long beep when turning on.
  - Display: it is directly driven by the CU. It receives the operation commands and the code of the characters to be displayed by the CU to which notifies the temporary availability to receive further data.
- The analog I/O -RS 232 can be divided in three parts:
  - Analog input: it is composed by a two-channels stage for impedance and gain control and moves the 2 analog input channels to the CU for the following A/D conversions and processing's.

- Analog output: it is composed by a quadruple D/A converter, driven by the CU, and a 3 channels level and impedance adapter stage.
- RS 232 :it is a levels translator. It matches the RS 232 signals to the digital standard ones (0V/5V). The CU is connected to this device by three output lines and same in input. It provide to qualify it during the printing, because the TX and RX are in share with the thermal printer.
- The power supply unit is mainly composed by two fundamental blocks:
  - Power supply :it is composed by the switching power supplies and the needed circuits in order to get the 5V for the logic and the 24 V for the thermal printer, the battery charge, as at the powerdown circuit and one protection circuit. The CU controls, through some input lines, the voltage whether at the thermal printer as at the accumulators and the A.C. main network. It chooses the power source for the printer, decides when to recharge the batteries and when to switch to the Powerdown State.
  - Printer control: the CU controls either the motor through 4 lines and the dedicated circuits, as thermal printer for what it concerns the operation signals and the data. Two protection circuits and two adapters inform the CU about an eventual too long strobe pulse, the overtemperature on the head, the open cover, the empty paper or the presence of the mark. The CU is responsible to calculate the duration of the strobe pulse (according to the printer voltage, the impedance, the head temperature and the selected paper speed).

## 2.1 Connections to external equipments

Delta 60 plus UPgradable version holds a "Cannon" connector for the analog I/O and RS 232

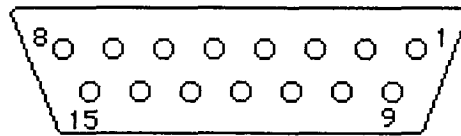

Pin	1	TX	(RS232)
"	2	RTS	" "
"	3	DSR	" "
"	4	GND	" "
"	5	IN CH2	
"	6	AGND	
"	7	OUT CH2	
"	8	N.C. (eventually 5V or 0 + 5 V see auxiliary output)	
"	9	DTR	(RS232)
"	10	RX	" "
"	11	CTS	" "
"	12	AGND (IN)	
"	13	IN CH1	
"	14	OUT CH1	
"	15	OUT	

Only equipment in accordance to the rules IEC 601-1 may be connected to this outlet and the connection itself must follow the safety regulations in force.

CARDIOLINE® supplies monitors and other equipment that may be connected with Delta 60 plus UPgradable version (please contact REMCO ITALIA S.p.A. before any connection).

### 2.1.1 ECG signal output.

Output features:

- standard amplitude: 0.5V/mV (modifiable to 0.25 V/mV or 1 V/mV, see Setup)
- Impedance: > 270  $\Omega$
- Signal dynamics:  $\pm 1.6$  V ( $\pm 3.2$  mV equivalent)

### 2.1.2 ECG signal input.

- standard sensitivity: 0.5 V/mV (modifiable to 0.25 V/mV or 1 V/mV, see Setup)
- Impedance: > 180 K $\Omega$
- Signal dynamics:  $\pm 3.2$  V ( $\pm 6.4$  mV equivalent)

### 2.1.3 RS 232-C bi-directional gate

- Input lines: there are three input lines with standard electrical features RS 232-C:
  - RX (receiver data)
  - DSR (data set ready)
  - CTS (clear to send)

Note:

DSR and CTS can be used in input for other purposes.

- Output lines: there are 3 output lines with electrical features following RS 232-C standard:
  - TX (transmitted data)
  - DTR (data terminal ready)
  - RTS (request to send)

Note:

DTR and RTS can be used in output for other purposes.

### 2.1.4 Auxiliary output

An auxiliary output is also available. This, if it is properly set, can provide + 5V to feed eventual low power circuits or an analog signal that can move from 0 and 2.5 V in 256 levels (see setup).

## 2.2 Check up of safety features

### 2.2.1 Instrumentation

- High voltage tester 4 KVAC
- Protective contact tester  $0.2 \Omega$   $10 \pm 25$  A
- Leakage current tester for medical equipments

### 2.2.2 Test of the supplied voltage

By using the high voltage tester, you have to supply the test voltage between the A.C. main connector and the ground point. The test voltage has to be 1.5 KVAC for class I equipments. At the beginning the supplied voltage value is no more than the half of the prescribed one. Thus you can high it within 10 seconds to the full value, and maintain it for one minute. During the test neither surface not destructive discharge have to appear. Some modest discharge can be put apart. They can appear due to the "crown effect" (Refer to the IEC 601/1 rules, par. 20.4).

### 2.2.3 Ground point test

By using the protective contact tester, you have to supply a current between 10 A and 25 A between the ground outlet and the ground terminal of the AC main cable. This current has to flow for at least 5 sec. The measured resistance must not exceed  $0.2 \Omega$  (Refer to the IEC 601/1 rules, par.18).

### 2.2.4 Leakage currents test

By using the leakage current tester you have to measure:

- the leakage current between the A.C. main connector and the ground of the equipment, or the outer case. The maximum acceptable value is 0.1 mA and 0.5 mA at the first failure for all the apparatuses (B-BF-CF).
- the leakage current between the patient cable and the ground, with A.C. main voltage at the patient cable. The maximum acceptable value is 0.05 mA for equipments type CF.
- the auxiliary current at the patient between every lead and the neutral one N: the maximum acceptable value is 0.01 mA.(refer to the IEC 601/1 rules par. 19).



## 2.3 Technical features check up

### 2.3.1 Instrumentation

- Calibrated mV source
- Sinusoidal frequencies, 1mV pp, source

### 2.3.2 Sensitivity and internal mV test

You have to connect to the positive pole of the calibrated mV source all the connectors C1, C2, C3 of the leads cable which is connected to the equipment. You have also to connect all the other connectors of this cable to the negative pole of the source.

You have to record the leads V1, V2, V3 at the sensitivity 20 mm/mV. Shortly press the button mV: the recorder signal must be in the range between 19 and 21 mm.

### 2.3.3 Paper speed test

You have to connect the positive pole of the sinusoidal frequencies source to the connector C1 of the leads cable, which has to be connected to the equipment. All the other connectors has to be connected to the negative pole of the source.

Pre-set the source on 1 Hz 1 mV pp and record the signal on the V1-V2-V3 lead.

Measure the paper speed: the maximum tolerance has to be  $\pm 5\%$ .

### 2.3.4 Frequency response test

You have to connect the connectors C1-C2-C3 of the leads cable, connected to the equipment, to the positive pole of the sinusoidal frequency source. All the other connectors has to be connected to the negative pole of the instrument.

Record the plot with sensitivity 10 mm/mV at the V1-V2-V3 lead.

Change the source frequency from 0.5 Hz to 100 Hz with constant amplitude 1 mV/pp.

Check the response plot with no filter inserted:

- From 0.5 to 60 Hz, the response has to be in between 9 mm and 10.5 mm.
- From 100 Hz up the response has to be in between 7 mm and 10.5 mm.

## 2.4 Open the equipment and get to the internal parts.

### 2.4.1 How to open the equipment

- Lean the equipment up side down, and unscrew the screws "A" (table 1)
- Turn the equipment on its natural position. Raise the upper case and lean it up side down against the worktable.(table 2)
- Disconnect the flat cable "A" (table 2) and separate the upper case in order to make easy the operations of removing the internal parts.

### 2.4.2 Disconnecting the analog board (5802200+5802201)

- Remove the flat cable which connects the CU "JP2" board (Table 4)
- Remove the patient outlet IN connectors "JP1" (Table 4)
- Unscrew the screws "A" (Table 3)
- To reassemble, place the board with the fixing holes in the vertical position and tight the 6 screws.

### 2.4.3 Disassembling the CU board (5802203+5802204)

- Unscrew the screws "B" (table 3).
- Remove the flat cables connected to JP1, JP2 and JP3 (Table 4) and pull the board out.

### 2.4.4 Disassembling the PW/printer board (5802205 or **5802210 x rel. ≥ 3.00**)

- Pull the screws "D" out (Table 3)
- Remove the flat cables connected to JP1, JP2, JP5, JP10, JP11, and printer connections board code 5802207 (or **5802211 x rel. ≥ 3.00**). (Table 4)

### 2.4.5 Disassembly the RSAIO board (5802198)

- Unscrew the fixing screws "C" (Table 3)
- Remove the "flat I/O" connected to JP2 and JP1

### 2.4.6 Disassembling the printer group (2820057)

- Pull out the fixing screws (Table 3,-E-)
- Remove the cables from the printer (3 cables: 1°- 6 wires, near motor; 2°- 6 wires, from paper sensor board; 3°- 20 wires)
- Remove the 6 cable connector JP1, from printer connections board code 5802207(or **5802211 x rel. ≥ 3.00**)
- Raise up the printer and put it in the vertical direction.

### 2.4.7 Disassembling the battery (7741715)

- The battery group is located near main switch (Table 4)
- Pull out the batteries group disconnecting the connector coming from the power supply/printer board

### 2.4.8 Disassembling the UPU peripheral board (5802208)

- Unscrew the 3 fixing screws "A" (table 5)
- Disconnect the flat cables connected to JP1 and JP4 (table 5).

TABLE 1

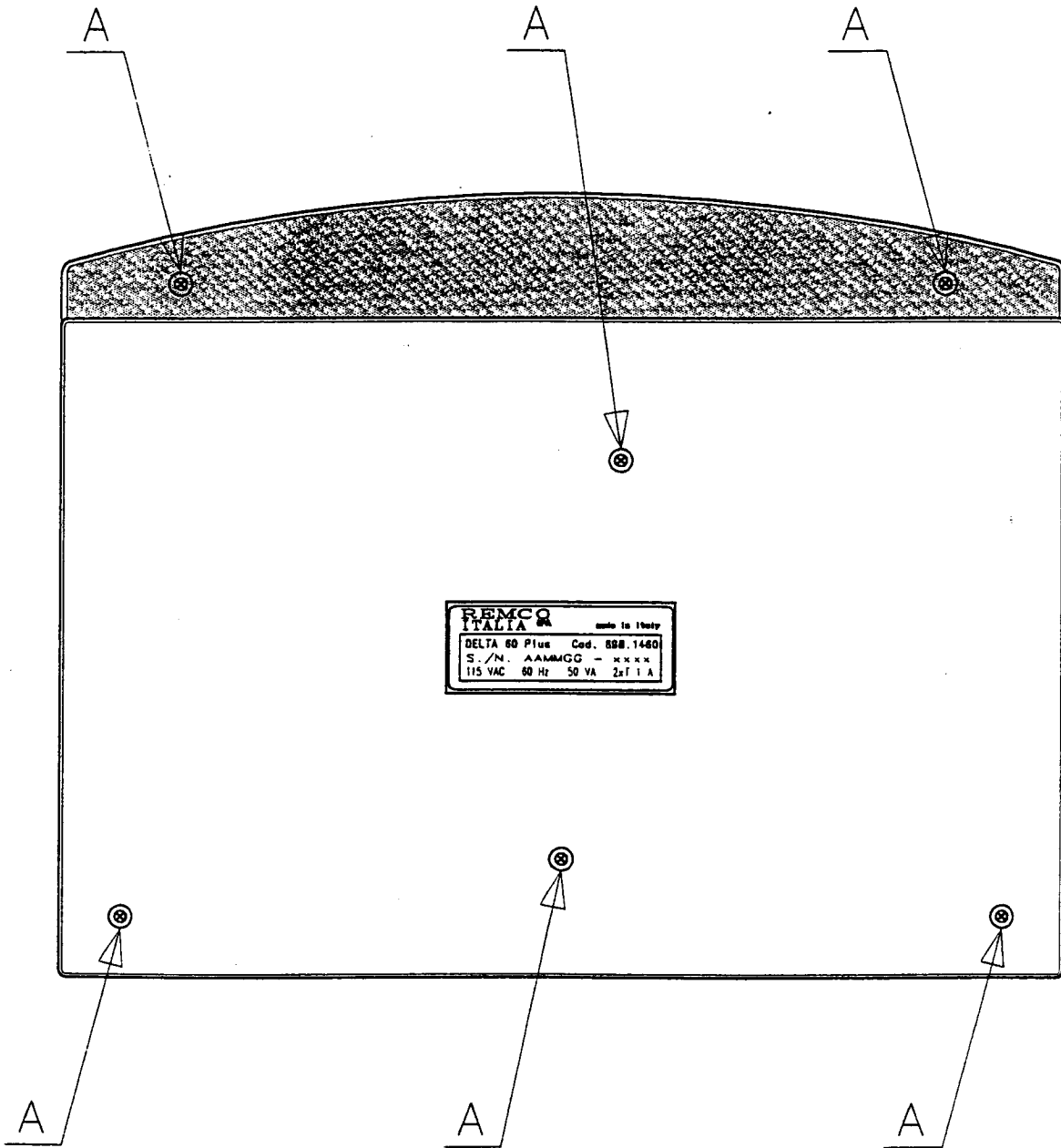

TABLE 2

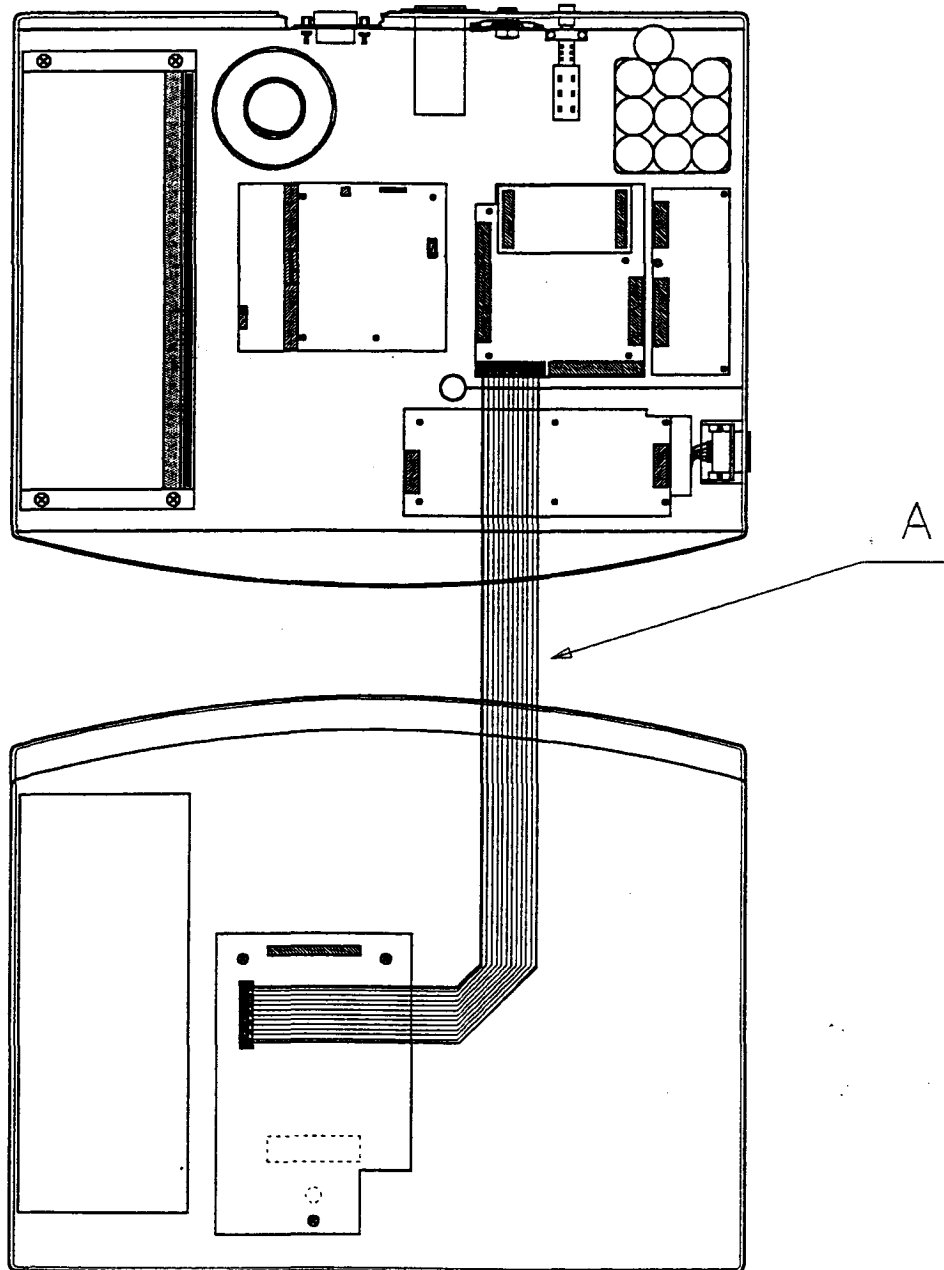

TABLE 3

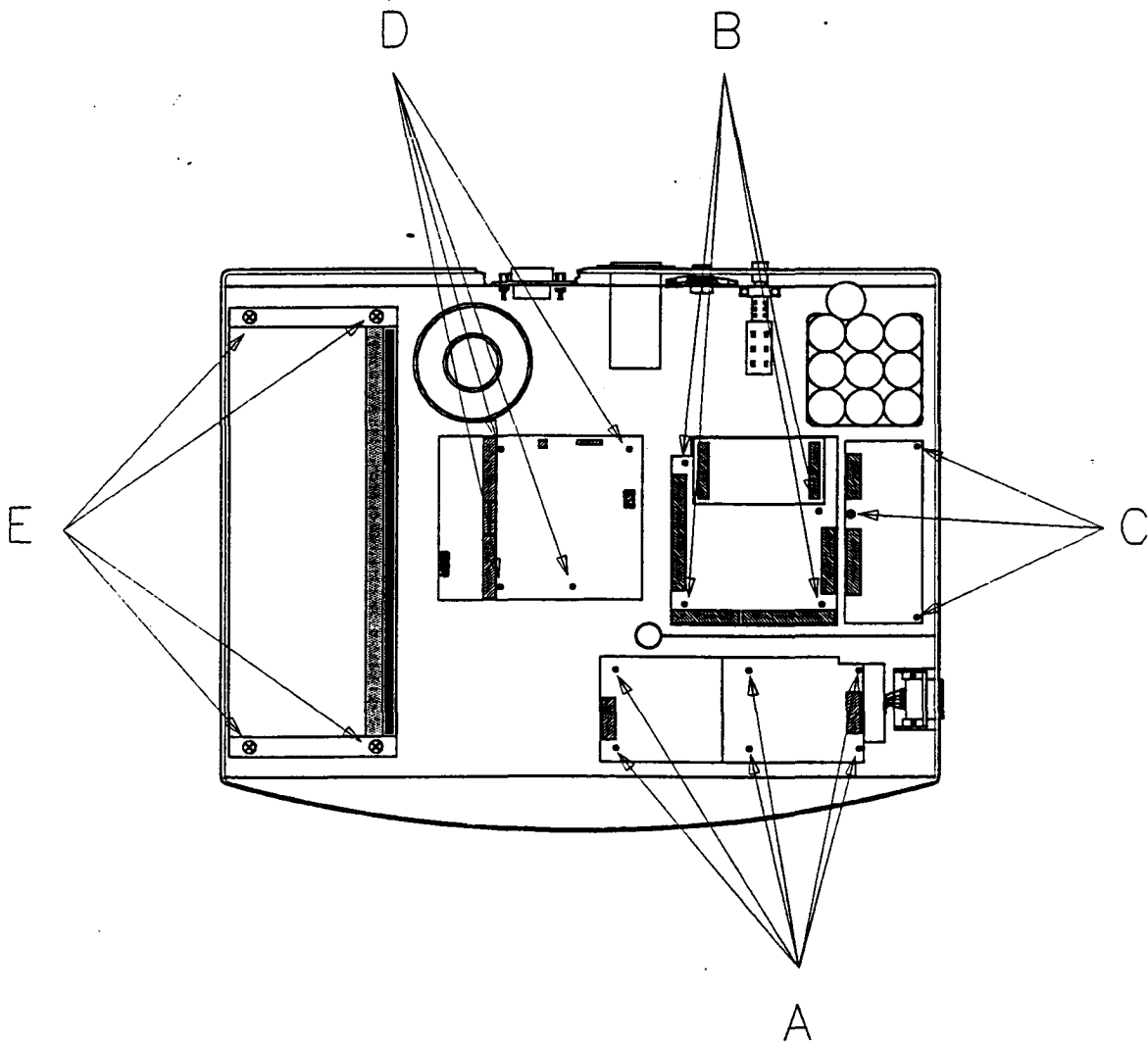

TABLE 4

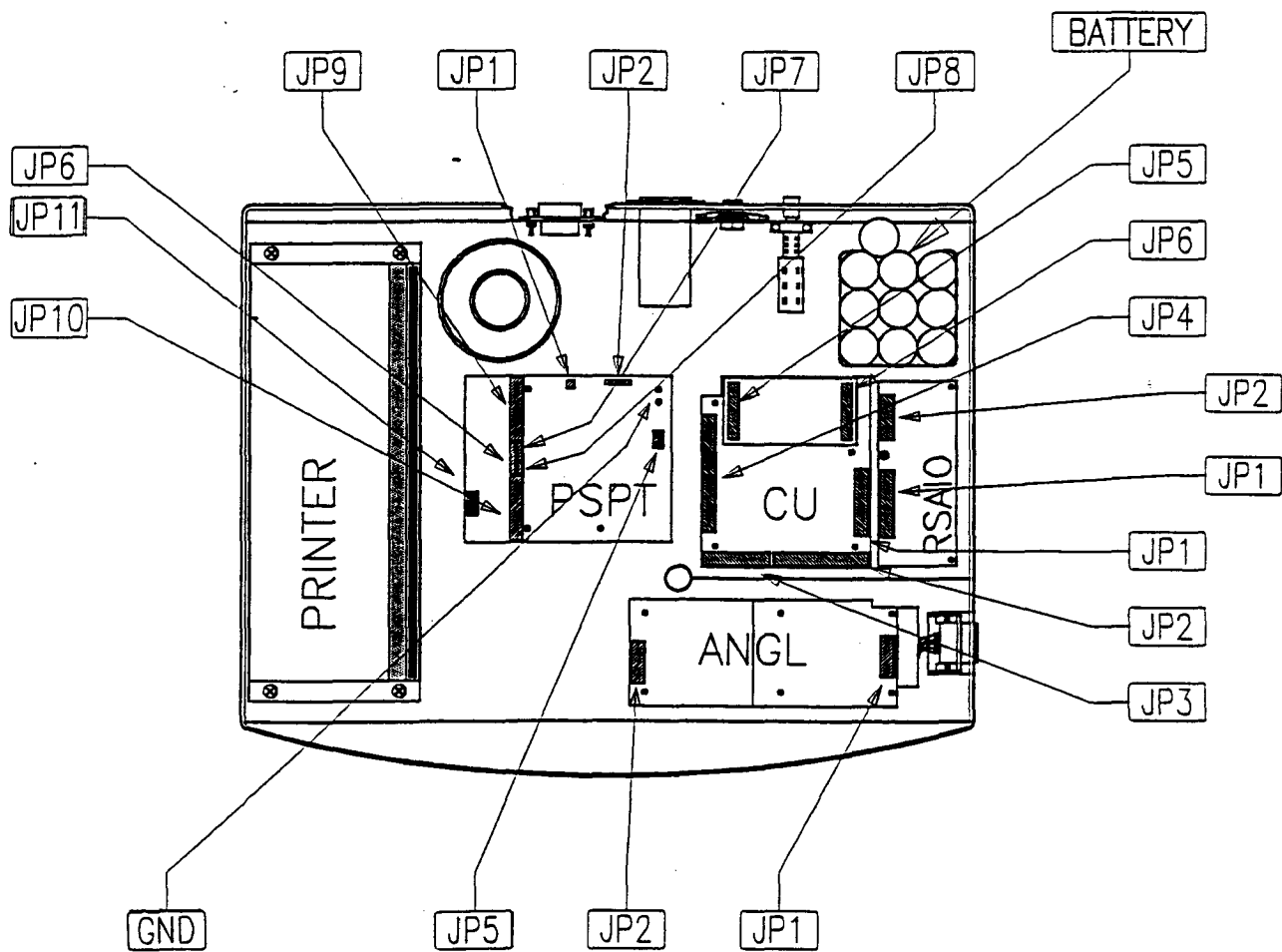
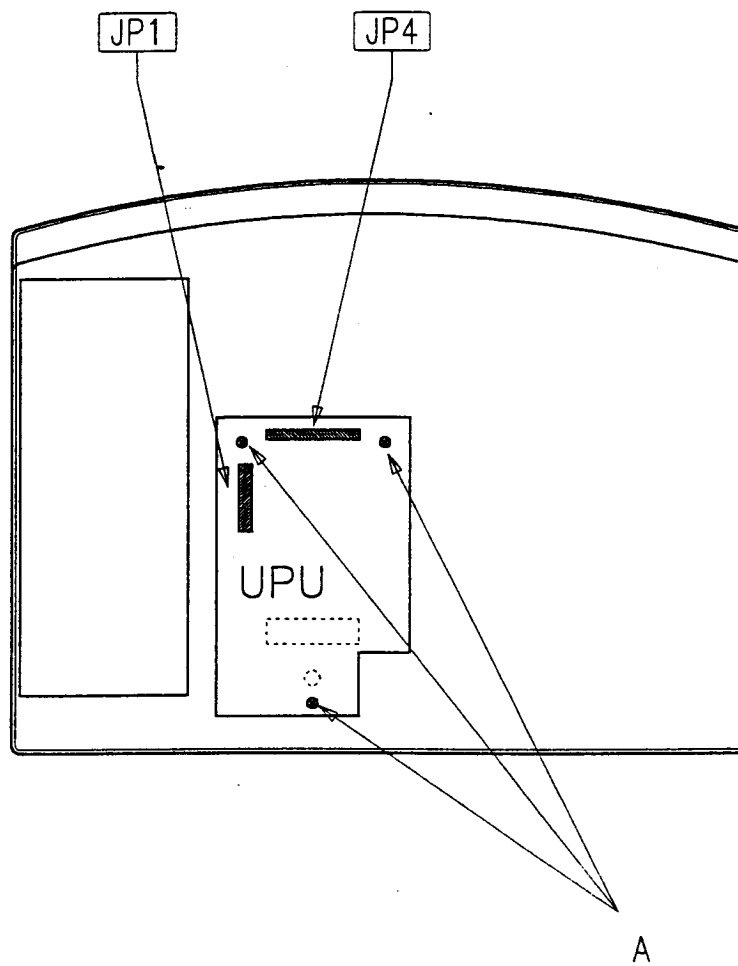

TABLE 5



### 3. Circuitry

#### 3.1 Analog boards (5802200+ 5802201)

##### 3.1.1 Functional description

The analog boards elaborates and amplifies the ECG signal at the patient cable leads. It takes the number of channels from 9 to 8: V1÷V6, D1, D2. These 8 channels are sequentially sent to a single line through a multiplexer, which 3 address lines are controlled by the CU board (code 5802203). The analog unit informs it about eventual saturation on the chest leads and/or the periferic ones. The analog unit receives also from the CU board the command INST and the power supply. The central unit acquires in the cyclic way the 8 channels and rebuilds the other 4 leads from D1 and D2 in the following way:

D3:	D2-D1
aVr:	-(D1+D2)/2
aVI:	(D1-D2)/2
aVf:	(D2-D1)/2

The analog unit is composed by two boards (codes 5802200 and 5802201) as it follows:

##### **5802200**

The first stage includes the gas discharges "S1÷S10" which, connected to the resistors "R1÷R10" and "U6", helps to save the rest of the circuit from defibrillation's potentials. The same resistors, together the capacitors "C1÷C9", form a low-pass filter. This filter eliminates the high-frequency noise. The diodes "D1÷D9", with their reverse current, polarise also the leads in order to be able to point out the lead disconnection. The U1 sections, A-B-C help to make the virtual centre, the Wilson Centre Terminal, used in the further stages as a reference. U3-B is the driving stage of the neutral lead. The negative feedback coefficient is quite high in order to reduce the effect of the common mode signal (mainly 50/60 Hz) at the signal ECG. U4 and U5 amplify the leads by a factor of 12.

##### **5802201**

U1, section C-D are the comparators which take the saturation of the chest leads through the dedicated component "ARD2".

U1 sections A-B are the comparators which take the saturation of the peripheral leads through "ARD1".

The coupling capacitors of the 8 channels C 5, 7, 9, 11, 13, 15, 17, 19, together the resistors R14, 17, 20, 23, 26, 29, 32, 35, define the time constant of 3.2 sec. U2 and U3 are buffer to gain = 1, used to insulate the eight lines driving to low impedance the R/C network and the next multiplexer. The R15-C6 ÷ R36-C20 network are used to limitate the "band signal" and to extend the Pace Maker pulses, because they are of small duration.

U4 is the multiplexer of the channels driven by the photo-couplers "ISO5÷ISO7".

U5 makes the function "INST", reducing the time constant into the coupling circuit U6 amplifies the multiplexed signal and drives in current the linear photo-coupler ISO3.

U10 converts from current to voltage the signal from ISO3 and adds an offset of 2.5 Volts. This in order to drive an input signal from 0 and +5V at the CU (code 5802203) A/D converter input.

The supply of the isolated circuitry is made by an oscillator. In this circuit there are also Q1 and Q2 and the transformer T1. The Shottky diodes bridge "DA1 ÷ DA4" rectifies the generated high frequency sinusoid, while the capacitors CA1 ÷ CA6 filter it.

U7 drives the decoded input of U4 and U5 (multiplexer) squaring the signals coming from the opto-coupler.

U8 and U9 are used to stabilize the insulated section power supply.



### 3.1.2 ANLG Connections

JP1 connector (5802200) to the patient cable

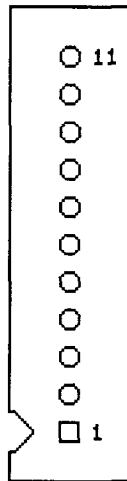

Pin1+Pin6	(I)	Chest leads C1+C6
Pin 7	(I)	Peripheral lead "R" (Right arm)
Pin 8	(I)	Peripheral lead "L" (Left arm)
Pin 9	(I)	Peripheral lead "F" (Left leg)
Pin 10	(O)	Common neutral
Pin 11		Isolated analog ground

JP3 connector (5802200) to the connector JP1 (5802201)



Pin 1	(I)	-5 Volts
Pin 2		Isolated analog ground
Pin 3	(O)	D1
Pin 4	(I)	+5 Volts
Pin 5	(O)	V1
Pin 6	(O)	D2
Pin 7	(O)	V3
Pin 8	(O)	V2
Pin 9	(O)	V5
Pin 10	(O)	V4
Pin 11	(O)	Common neutral
Pin 12	(O)	V6

Connector JP2 to the CU board (5802203)

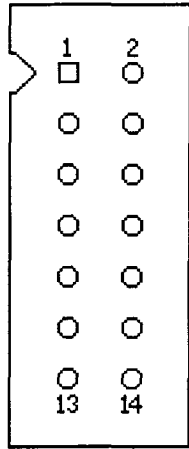

Pin 1		Analog ground
Pin 2	(O)	Peripheral leads saturation (active low)
Pin 3	(O)	Chest leads saturation (active low)
Pin 4	(O)	Analog signal containing the 8 multiplexed Ch
Pin 5	(I)	Bit 2 channels selection (active low)
Pin 6	(I)	Bit 1 channels selection (active low)
Pin 7	(I)	INST command (active low)
Pin 8	(I)	+5 Volts power supply
Pin 9	(I)	Bit 0 channels selection (active low)
Pin 10		Power supply ground
Pin 11	(I)	Insulated stage power supply activation (active low)
Pin 12		n.c.
Pin 13		n.c.
Pin 14		n.c.

## 3.2 CU board (5802203)

### 3.2.1 Functional description

This board is the heart of the system. As a matter of fact it manages the operations of all the other board and peripheral units. It holds the "brain" of the data processing.

The Microcontrollers used are a <80C196KC> at 16 MHz/16 bit ("U1") and a <80C198> at 12 MHz/8 ("U14").

The RAM of job of '196 is in MEM board (5802204) that through JP5 and JP6 is connected on CU board.

The 80C196KC have an addressing space of 64 Kbytes that was not sufficient to maps all the devices connected to it, therefore U6 and U9 helped this function.

U2 is used to generate a reset pulse when the power supply go down under about 4.5 Volt, U3 is a "Vref" voltage generator for the A/D converter located in the Microcontroller, U4 and U5 are used to separate the data lines from the address lines.

U6, U7 and U8 are "GAL" (Gate Array Logic) and constitutes the address decode logic, the buffer control (Buf\_198) of interchange between the Microcontrollers.

U10 and U11 are the selection pages circuits RAM/Fep and respectively in Pg\_addr = 2 and 3, U12 is the register "Reg".

U16 is the "Buf\_198", a RAM of 32 K x 8 that may be shares from the Microcontrollers.

U17, U18 and U19 are the interface toward the '196.

U15 is used to separate the address from the data for the '198.

### 3.2.2 CU connections

JP2 connector to the power supply/printer board and analogue board (5802205 or **5802210 x rel.  $\geq 3.00$  e 5802200**)

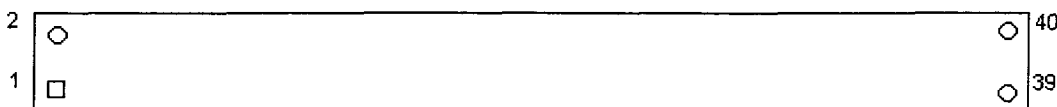

Pin 1	(I)	F3	Pin 2	(O)	VCC	Pin 3	(O)	GND
Pin 4	(O)	VCC	Pin 5	(O)	GND	Pin 6	(O)	AGND2
Pin 7	(I)	DT CLK	Pin 8	(I)	DT OUT	Pin 9	(I)	F O
Pin 10	(I)	D U T	Pin 11	(I)	BC ON	Pin 12	(I)	PS OFF \
Pin 13	(I)	F 1	Pin 14	(I)	F 2	Pin 15	(I)	L T C
Pin 16	(O)	STAL \	Pin 17	(O)	THAL \	Pin 18	(O)	HUP \
Pin 19	(O)	PE	Pin 20	(I)	AN 3	Pin 21	(I)	STROBE
Pin 22	(O)	AN 4	Pin 23	(I)	STIN \	Pin 24	(O)	AN 2
Pin 25	(I)	24 B	Pin 26	(O)	AN 1	Pin 27	(I)	24 T
Pin 28	(O)	V T	Pin 29	(O)	24 RF	Pin 30	(O)	AGND 1
Pin 31	(O)	OL \	Pin 32	(O)	VOL \	Pin 33	(O)	AN 0
Pin 34	(I)	CHC	Pin 35	(I)	CHB	Pin 36	(I)	INST \
Pin 37	(I)	VCC	Pin 38	(I)	CHA	Pin 39	(I)	GND
Pin 40	(I)	ST \						

JP1 connector to the RS232/Analog I/O board (5802198)

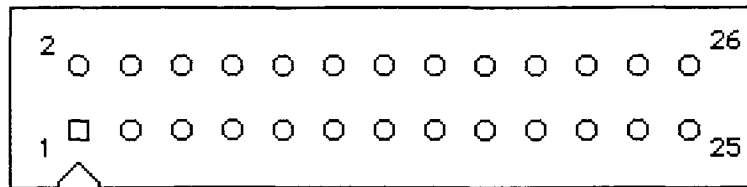

Pin 1,3,5,7,9,11,13,15	(I/O)	Data bus (D0÷D7)
Pin 2	(O)	Bit 1 of the address bus
Pin 4	(O)	Bit 0 of the address bus
Pin 6	(I)	Data Set Ready signal
Pin 8	(I)	Clear To Send signal
Pin 10	(O)	RS232 board on (active low)
Pin 12	(O)	Request To Send signal
Pin 14	(O)	Data Terminal Ready signal
Pin 16	(O)	Output of + 5 Volts reference voltage, generated by U16
Pin 17	(O)	Chip Enable for the D/A converter
Pin 18	(I/O)	RXD line from the RS232 board. It works also as data output
Pin 19	(O)	TXD line to the RS232 board. It works also as data clock in the synchronous mode.
Pin 20		Digital logic power supply ground
Pin 21		Digital logic power supply ground
Pin 22	(O)	+5 Volts digital logic power supply
Pin 23	(O)	+5 Volts digital logic power supply
Pin 24	(I)	Auxiliary analog signal, channel 1
Pin 25	(I)	Analog ground
Pin 26	(I)	Auxiliary analog signal, channel 2

JP3 connector to the UPU board (5802208)

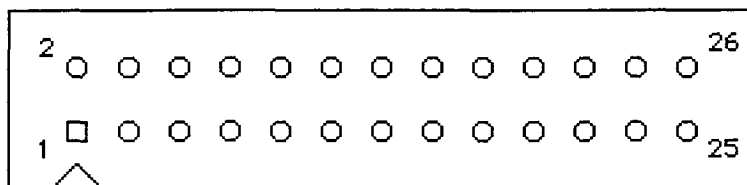

Pin from 1 to 8	(I/O)	Data bus (D0÷D7)
Pin 9	(O)	Chip Enable for the Buzzer control logic.
Pin 10	(O)	Chip Enable of Clock/RAM
Pin 11	(O)	Chip Enable of the keyboard scanner circuit
Pin 12	(O)	Chip Enable of Clock/RAM
Pin 13	(I)	Chip Enable of Clock/RAM
Pin 14	(O)	Data selection (high) and instructions (low) for the Display
Pin 15	(O)	Reset (active low)
Pin 16	(O)	Power supply +5 Volts of the digital logic
Pin 17		Digital logic power supply ground
Pin 18		Digital logic power supply ground
Pin 19		N.C.
Pin 20	(O)	Valid address (active low)
Pin 21	(O)	Reading command (active low)
Pin 22	(O)	Reading command (low)/writing (high) for the display
Pin 23	(O)	Power supply line of the LED of the UPU board (5802208)
Pin 24	(O)	Writing command (active low)
Pin 25	(I)	Active line low if the Start/stop button is pressed
Pin 26	(O)	Chip Enable of the display

JP4 to the Flash card and Graphic display



Pin 1 (I) ALE	Pin 2 (I) GND	Pin 3 (I/O) D 15
Pin 4 (I/O) D 14	Pin 5 (I/O) D 13	Pin 6 (I/O) D 12
Pin 7 (I/O) D 11	Pin 8 (I/O) D 10	Pin 9 (I/O) D 9
Pin 10 (I/O) D 8	Pin 11 (I) WRH \	Pin 12 (I) DEC2
Pin 13 (I) CEDV2 \	Pin 14 (I/O) D 7	Pin 15 (I/O) D 6
Pin 16 (I/O) D 5	Pin 17 (I/O) D 4	Pin 18 (I/O) D 3
Pin 19 (I/O) D 2	Pin 20 (I/O) D 1	Pin 21 (I/O) D 0
Pin 22 (I) WRL \	Pin 23 (I) RD \	Pin 24 (I) CEDPG \
Pin 25 (I) VCC	Pin 26 (I) VCC	Pin 27 (I) GND
Pin 28 (I) AD 0	Pin 29 (I) AD 1	Pin 30 (I) AD 2
Pin 31 (I) AD 3	Pin 32 (I) AD 4	Pin 33 (I) AD 5
Pin 34 (I) AD 6	Pin 35 (I) AD 7	Pin 36 (I) AD 8
Pin 37 (I) AD 9	Pin 38 (I) AD 10	Pin 39 (I) AD 11
Pin 40 (I) AD 12	Pin 41 (I) AD 13	Pin 42 (I) CEDV1 \
Pin 43 (I) CEFC \	Pin 44 (I) VPFC	Pin 45 (I) LOCK
Pin 46 (I) RESET	Pin 47 (I) DEC 1	Pin 48 (I) P2.2
Pin 49 N. C.	Pin 50 (I) 24 RF	

### 3.3 MEM board (5802204)

#### 3.3.1 Functional description

This board holds the job memory of the 80C196KC subdivided in a Flash Eprom (FEP) of 2 Mbit (256 KByte) or of 4 Mbit (512 Kbytes) and in two or four chip of RAM of 1 Mbit (two = 256, four = 512).

U1 is the Fep word organized (16 bit) that inside holds the blocks as follow:

- 2 Mbit version : "Boot (16 KB), Parameter 1 (8 KB), Parameter 2 (8KB), Main 1 (96 KB), Main 2 (128 KB)"
- 4 Mbit version : "Boot (16 KB), Parameter 1 (8 KB), Parameter 2 (8KB), Main 1 (96 KB), Main 2 (128 KB)", Main 3 (128 KB), Main 4 (128 KB)

The "Boot block" is write with dedicated external programmer and when this board is connected on CU board this block can not be modified, in this mode is possible to restore the unit also after a faulty without problem of firmware routines.

The "Parameters Blocks" holds information about system configuration.

The "Main Blocks" holds the program of the unit.

The Fep is mapped in 32 pages of 16 Kbytes by means the FA14÷FA18 lines.

"RG1" with its circuitry is a 12 Volt regulator that is active when a modify of some Fep data is required.

U2, U3, U4 and U5 are the RAM mapped in 16 pages of 16 Kbytes each one by means RA14÷RA17 lines.

The separated lines of CHIP-SELECT "Ceram1\ and Ceram2\ multiplies for two pages sow from the microcontroller, in this mode there are available 32 pages of 16 KB when are mounted four chips.

### 3.3.2 MEM Connections

JP5 to MEMORY board (5802204) MEM\_1

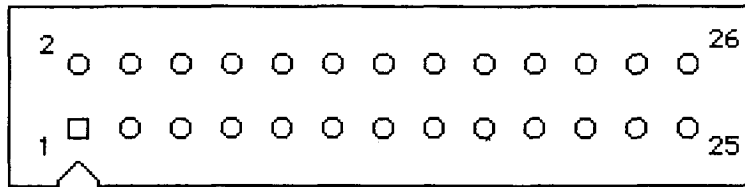

Pin 1 (I)	AD 12	Pin 2 (I)	AD 13
Pin 3 (I)	AD 10	Pin 4 (I)	AD 11
Pin 5 (I)	AD 8	Pin 6 (I)	AD 9
Pin 7 (I)	AD 6	Pin 8 (I)	AD 7
Pin 9 (I)	AD 4	Pin 10 (I)	AD 5
Pin 11 (I)	AD 2	Pin 12 (I)	AD 3
Pin 13 (I/O)	D 15	Pin 14 (I)	AD 1
Pin 15 (I/O)	D 14	Pin 16 (I/O)	D 13
Pin 17 (I/O)	D 12	Pin 18 (I/O)	D 11
Pin 19 (I/O)	D 10	Pin 20 (I/O)	D 9
Pin 21 (I/O)	D 8	Pin 22 (I)	WRH \
Pin 23 (I)	RD \	Pin 24 (I)	VCC
Pin 25	N. C.	Pin 26 (I)	VRL \

JP6 to MEMORY board (5802204) MEM\_2

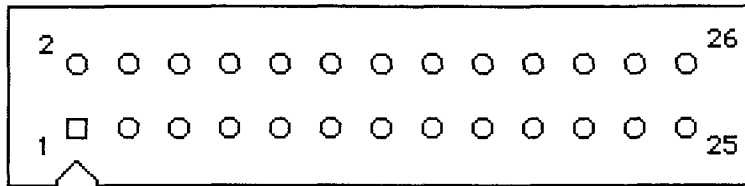

Pin 1	N. C.	Pin 2 (I)	RA 14
Pin 3 (I)	RA 16	Pin 4 (I)	RA 15
Pin 5 (I)	FA 14	Pin 6 (I)	RA 17
Pin 7 (I)	FA 16	Pin 8 (I)	FA 15
Pin 9 (I/O)	D 1	Pin 10 (I/O)	D 0
Pin 11 (I/O)	D 3	Pin 12 (I/O)	D 2
Pin 13 (I/O)	D 5	Pin 14 (I/O)	D 4
Pin 15 (I/O)	D 7	Pin 16 (I/O)	D 6
Pin 17 (I)	CERAM 1 \	Pin 18 (I)	AD 15
Pin 19 (I)	FA 18	Pin 20 (I)	CERAM 2 \
Pin 21 (I)	VPFE	Pin 22 (I)	FA 17
Pin 23 (I)	VCC	Pin 24 (I)	24RF
Pin 25 (I)	GND	Pin 26	N. C.

## 3.4 User Peripheral Board UPU (5802208)

### 3.4.1 Functional description

This board is prevalently dedicated to the functions of interface to the user. This functions are the keyboard, the display and the buzzer. It contains also the Clock/RAM device used either as Clock/Calendar than to store several operational parameters related to the system setup.

U1 is a PLD (Programmable Logic Device) that performs three functions: The scanner keyboard with "3-state" output, the buzzer controller and the "chip-select" generator for Clock/RAM.

U2 is the Clock/RAM holding an internal lithium battery in order to work even without an external power supply. The access to this device is at 8 bit in reading and in writing. This device, if properly programmed, provides to the pin "SQW" a square wave at the frequency of 4096 Hz used by the buzzer control circuit and the keyboard scanner.

In the control buzzer section of U1 are charged the first 4 bit of data bus, with decimal value between 0 and 15; every value different from 0 make so that the system count down with a 256 Hz (period = 4ms); in this mode is activated a gate that send a 4.096 Khz carrier to the buzzer for a time between 4 ms equal to codes 1 and 60 ms equal to codes 15.

The keyboard is organized in "button matrix" save that "ctrl and "shift" keys. The scanning is made by driving alternatively the 8 columns (Y1÷8 pins) and testing the 8 rows (X1÷8 pins). In output are supplied 8 bits organized in 3 groups to indicate pressure of "Shift" (D7), "Ctrl" (D6) and the other 58 keys (D5÷0).

LCD is the Display with 2 rows and 16 columns where it can be accessed at 8 bits in writing and in reading.

### 3.4.2 UPU Connections

JP1 connector to the CU board (5802203)

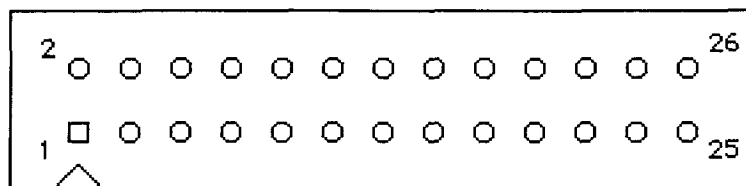

Pin 1+ Pin 8	(I/O)	Data bus (D0+D7)
Pin 9	(I)	Chip Enable of the buzzer logic control
Pin 10	(I)	Chip Enable of the Clock/RAM
Pin 11	(I)	Chip Enable of the keyboard scanner circuit
Pin 12	(I)	Chip Enable of the Clock/RAM
Pin 13	(O)	Chip Enable of the Clock/RAM
Pin 14	(I)	Data selection (high) and instructions (low) for the display
Pin 15	(I)	Reset (active low)
Pin 16	(I)	+5 Volts
Pin 17		ground
Pin 18		ground
Pin 19		N.C.
Pin 20	(I)	Valid address (active low)
Pin 21	(I)	Reading command (active low)
Pin 22	(I)	Reading command (low)/writing (high) for the display
Pin 23	(I)	Power supply line of the LD1 LED
Pin 24	(I)	Writing command (active low)
Pin 25	(O)	Active line low if the Shift button is pressed
Pin 26	(I)	Chip Enable of the display

JP2 connector to the display

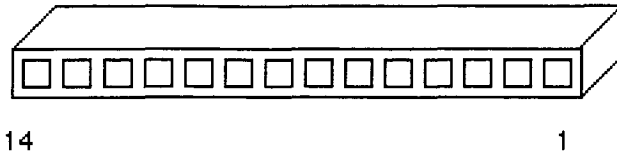

Pin 1		Ground
Pin 2		+5 Volts
Pin 3		Polarization voltage for the contrast
Pin 4	(O)	Data (high) and instructions (low) selection for the display
Pin 5	(O)	Reading command (low) /writing (high) for the display
Pin 6	(O)	Chip Enable of the display
Pin 7+14	(I/O)	Data bus

JP4 connector to the keyboard

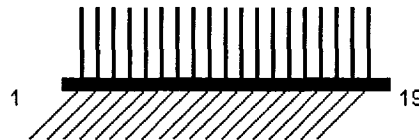

Pin 1	(O)	Y 1
Pin 2	(O)	Y 2
Pin 3	(O)	Y 3
Pin 4	(O)	Y 4
Pin 5	(I)	X 1
Pin 6	(I)	X 2
Pin 7	(I)	X 3
Pin 8	(I)	X 4
Pin 9	(I)	X 5
Pin 10	(I)	X 6
Pin 11	(I)	CT
Pin 12		COM
Pin 13	(I)	SH
Pin 14	(I)	X 7
Pin 15	(I)	X 8
Pin 16	(O)	Y 5
Pin 17	(O)	Y 6
Pin 18	(O)	Y 7
Pin 19	(O)	Y 8



## 3.5 Power Supply/Print. Board PSPT (5802205 or 5802210 x rel. $\geq$ 3.00)

### 3.5.1 Functional description

The board is composed by two fundamental groups:

- **Power supply:** it includes the switching power supplies and the circuits that are needed to get the 5V for the logic and the 24V for the thermal printer, the battery charger, the "Powerdown" circuit and a protection circuit. The CU controls, through several input lines, either the voltage at the thermal head as the state of the accumulators and the A.C. main supply. It decides also how to feed the printer (which source), when to recharge the accumulators and when to pass to the "Powerdown" state.
- **Printer control:** the CU through 4 lines and the dedicated circuitry controls the step by step motor. The head is directly connected to the CU, regarding the operational signals and the data. Two protection circuits and two adapters inform the CU about an eventual too long strobe pulse, the over temperature of the head, the paper cover that could be raised up, absence of paper or the presence of the mark.

**Warning: on Delta 60 version  $\geq$  3.00, the power supply board is coded 5802210, and the adapter printer board is coded 5802211.**

RG1 is the battery charging circuit which, due to the resistors R5 and R5A (17.8  $\Omega$ ) provides a constant current of 140 mA (1/10 C). The CU turns on and off this circuit through Q1 and Q2. M1 is a MOSFET driven by the "Powerdown" circuit, which can be disabled by the CU in order to disconnect the battery when the equipment self-turns on.

RG2 represents the switching step down power supply, which provides around 24 Volts to the thermal printer, leaving from the transformer voltage. The activation is made by Q3, which is driven by the 24T and B lines. RG3 is the switching power supply "step down" that gives 5 volt starting from transformer or battery voltages.

U1 with its circuit are a protection circuit which, when the battery or transformer are under 17 Volts, inhibits through Q11 the activation either of RG2 than M2 to protect the thermal printer. U5 is the "Powerdown" circuit which is always fed by the battery (current absorption 40  $\mu$ A circa) and allows to take out or in this one respectively from the CU and from the SHIFT button.

M8 allows to feed the motor driving circuit and the LED of the mark detector only when the printer 24 Volts (5PTON\low) are active. This avoids an over consumption of the battery.

RG4 is a linear regulator that powered from the transformer or battery and actived by M9, supplies about 20 volt for the CU board (feeding of Vref voltage and for Flash programmer when is present).

M4-M7 drives the motor coils.

M3 with Q15, allows to reduce the overheating of the motor in the case of very long printouts and the consumption contemporary.

U3 squares the Strobe, Cover open and Paper empty signals.

U4-A protects the thermal head in case of too long strobe pulses, putting down the STAL\ line.

U4-B- protects the thermal head in case of over temperature, putting down the THAL\ line.

### 3.5.2 PSPT connections

JP1 connector to the transformer:

Pin 1,2            (I)        Secondary voltage of the transformer

JP6 connector to the motor:

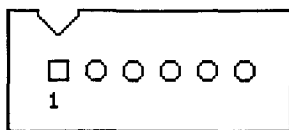

- Pin 1 and 2 (O) Common lines to the four phases (nominal 24 Volts/5 Volts)
- Pin 3 (O) Phase 1
- Pin 4 (O) Phase 2
- Pin 5 (O) Phase 3
- Pin 6 (O) Phase 4

JP7 connector to the mark sensor

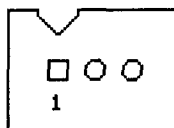

- Pin 1 (O) Led power supply
- Pin 2 Ground
- Pin 3 (I) Output of the phototransistor which signals the mark or the paper absence (active low)

JP8 connector to the raised head sensor

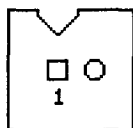

- Pin 1 (I) High line if the head is raised up or the paper absence
- Pin 2 Ground

JP9 connector to the thermal head

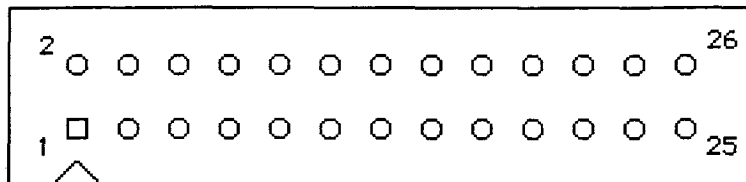

- Pin 1,3,5,21,23,25 (O) Power supply of the thermal head dots (nominal 24 Volts)
- Pin 2,4,6,22,24,26 Ground
- Pin 7 (O) Data latch into the shift register of the thermal head
- Pin 8 (O) Serial data
- Pin 9+14 (O) Strobe lines
- Pin 15 and 16 (I) Outputs from the thermistor
- Pin 18 (O) +5 Volts power supply of the thermal head logic
- Pin 19 (O) Data clock (rising edge)

JP10 connector to the Central Unit board

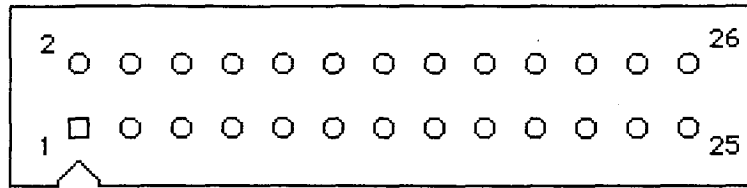

- Pin 1 (O) +5 Volts power supply of the digital logic
- Pin 2 Digital logic power supply ground
- Pin 3 Analog ground
- Pin 4 (I) Data clock sent to the thermal head. It works also as TXD line in the asynchronous mode
- Pin 5 (I) Data line sent to the thermal head
- Pin 6 (I) Phase Ø of motor
- Pin 7 (I) Duty Cycle of Motor
- Pin 8 (I/O) Activation of the battery charger (active high) in output, verify of the insertion of the jumper JP3 in input
- Pin 9 (I) Switching off of the power supply when working at battery (active low)
- Pin 10 (I) Selection of the motor step (phase 1)
- Pin 11 (I) Selection of the paper feed direction (phase 2)
- Pin 12 (I) Command of the latches of the thermal head (latched dots if low)
- Pin 13 (O) Alarm on the thermal head strobe (active low)
- Pin 14 (O) Alarm on the thermal head temperature(active low)
- Pin 15 (O) Raised head (active low)
- Pin 16 (O) Presence of the paper mark or paper absence (active high)
- Pin 17 (O) Analog signal 1/11 of the power supply voltage of the thermal head
- Pin 18 (I) Strobe pulse at the thermal head
- Pin 19 (O) Analog signal reverse proportional to the thermal head temperature
- Pin 20 (I) Active line low if the SHIFT button is pressed
- Pin 21 (O) Analog signal 1/11 of the battery voltage
- Pin 22 (I) Printer power supply by the battery (active high)
- Pin 23 (O) Analog signal 1/11 of the main power supply after the transformer, rectifier and filter
- Pin 24 (I) Printer power supply by the main (active high)
- Pin 25 (O) Power supply line of the LED of the UPU board (5802208)
- Pin 26 (O) +24 nominal Volts power supply of U16 in the CU board (5802203+5802204)

JP11 connector to the CU

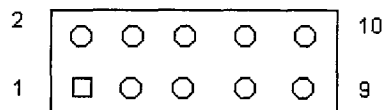

- Pin 1 (O) + 5 Volt of the printer
- Pin 2 (I) Phase 3 of the motor
- Pin 3 (O) + 5 Volt of power supply
- Pin 4-5 GND
- Pin 6 (I) Selection line of U2
- Pin 7,8,9,10 n.c.

### 3.6 I/O board -RSAIO- (5802198)

The analog I/O board - RS 232 can be divided into three parts:

- Analog input: it is made by a two channels stage which matches the impedance of the input signal and amplifies it, moving it to the CU for the further A/D conversions and processing's.
- Analog output: it includes a D/A quadruple converter, which is driven by the CU and a 3 channel stage which adjust the level and the impedance.
- RS232: it is a level translator, which matches the RS232 levels to those standard digital (0V+5V) and viceversa. The CU is directly connected to this device with three output and three input lines. It provides to disable it during the printout phase, because the TX and RX lines are shared to the thermal printer.

U1 inverts the power supply voltage of +5 Volts, obtaining -5 Volts nominal. U2-A-B-C represents the amplification circuit of the two analog input channels with an output offset of 2.5 Volts. U3 is the level translator for the RS 232 signals. It has three input lines and four ones in output. One of them is not used. Moreover it holds an enabling line and a powerdown one. U2-D is a low output impedance buffer, which is used as a voltage reference of the quadruple D/A converter. U5 is the D/A quadruple converter, which receives the codes by the CU and outputs the four analog signals. U4 is a circuit, which generates a WRITE command for U5. U6 is the output stage for the bipolar amplification.

#### 3.6.1 RSAIO connections

JP1 connector to the Central Unit board (5802203)

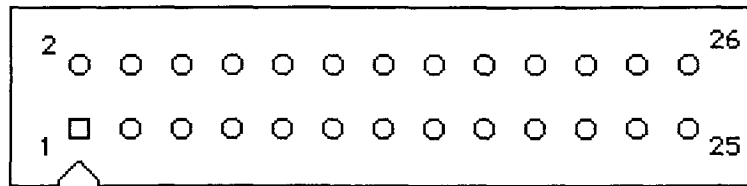

Pin 1,3,5,7,9,11,13,15	(I/O)	Data bus (D0+D7)
Pin 2	(I)	Bit 1 of the addresses bus
Pin 4	(I)	Bit 0 of the addresses bus
Pin 6	(O)	Data Set ready signal
Pin 8	(O)	Clear to Send signal
Pin 10	(I)	RS232 module enabling
Pin 12	(I)	Request to Send signal
Pin 14	(I)	Data Terminal Ready signal
Pin 16	(I)	Reference voltage +5 Volts input
Pin 17	(I)	Chip Enable for the D/A converter
Pin 18	(I/O)	RXD line from RS 232 module. It works also as data output in the synchronous mode
Pin 19	(I)	TXD line to the RS232 module. It works also as data clock in the synchronous mode
Pin 20		Power supply ground
Pin 21		Power supply ground
Pin 22	(I)	+5 Volts power supply
Pin 23	(I)	+5 Volts power supply
Pin 24	(O)	External analog signal, channel 1
Pin 25		Analog ground
Pin 26	(O)	External analog signal, channel 2

## JP2 I/O connector

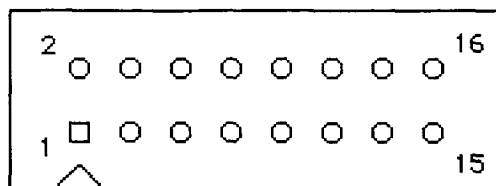

Pin 1	(O)	TX (RS232)
Pin 2	(O)	Data Terminal Ready (RS232)
Pin 3	(O)	Request to send (RS232)
Pin 4	(I)	RX (RS232)
Pin 5	(I)	Data Set Ready (RS232)
Pin 6	(I)	Clear to Send (RS232)
Pin 9	(I)	Analog channel 2 input
Pin 10	(I)	Analog channel 1 input
Pin 12	(O)	Analog channel 1 output
Pin 13	(O)	Analog channel 2 output
Pin 14	(O)	Analog channel 3 output
Pin 15	(O)	Analog channel 4 output
Pin 16		N.C.

## 4. Setup

### 4.1 HW Setup

There are no accessible switches from outside because all the setup concerning the user are effectuated through a particular setup menu and are stored into the Clock/RAM chip in the UPU board (code 5802206).

Therefore there are some setup and jumpers that have to be done during the service. There are:

- **ECG input board setup:** referring to the electric diagram of the ECG/INPUT board (5802200), there are 8 trimmers PT1+PT8 which calibration has to be effectuated when checking up the analog board.
- **Analog trimmer board setup:** referring the electric diagram of the ANLG board (code 5802201), there are 3 multirounds trimmers that have the following functions:

PT1: gain calibration

PT2: linear photocoupler ISO 3 work point calibration

PT3: output offset calibration

The calibration of these trimmers is assisted by a program which is included into the dedicated test procedures. In case of failure, it is better to change the whole board.

- **RSAIO board (5802198) setup:** This is the input sensitivity setup. The standard value of sensitivity is 1 cm/0.5 V at 10 mm./mV. The input signal dynamic is  $\pm 3.2$  V with a resolution of 6.25 mV. It corresponds to a dynamic of  $\pm 6.4$  mV that equivalent with a resolution of 12.5  $\mu$ V equivalent. Other values of sensitivity can be set by changing the resistors R6, R9, R10, R13 as follows:

- **1cm/0.25 V:** R6, R9, R10, R13 equal to  $41.200 \Omega \pm 1\%$ . The input signal dynamic is  $\pm 1.6 \text{ V}$  with a resolution of  $3.125 \text{ mV}$  which correspond to a dynamic of  $\pm 6.4 \text{ mV}$  equivalent with a resolution of  $12.5 \mu\text{V}$  equivalent.
- **1cm/1 V:** R6, R9, R10, R13 equal to  $165.000 \Omega \pm 1\%$ . The input signal dynamic is  $\pm 3.2 \text{ mV}$  with a resolution of  $6.25 \text{ mV}$  which correspond to a dynamic of  $\pm 3.2 \text{ mV}$  equivalent with a resolution of  $6.25 \mu\text{V}$  equivalent.
- **Output level setup:** the standard output level is  $0.5 \text{ V/1 cm}$  at  $10 \text{ mm/mV}$ . The output signal dynamic is  $\pm 1.6 \text{ V}$  that are equivalent to a dynamic of  $3.2 \text{ mV}$  equivalent.

Several sensitivity values can be set, by properly jumping JP4 as in fig.1:

- **0.25V/1 cm.** The output signal dynamic is  $\pm 0.8 \text{ V}$  that are equivalent to a dynamic of  $3.2\text{-mV}$  equivalent.
- **1 V/1 cm.** The output signal dynamic is  $\pm 3.2 \text{ V}$  that are equivalent to a dynamic of  $3.2\text{-mV}$  equivalent.

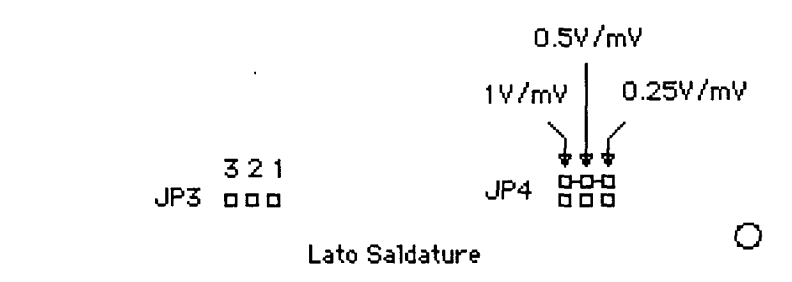

Fig.1

- **Output fourth channel setup:** a floating auxiliary output is at the JP2 connector. Through JP3, this output can be connected to + 5 Volts (Pins 1 and 2 shorted) in order to feed low consumption outer circuits. It can be connected also to the fourth channel of the D/A converter (Pins 2 and 3 shorted), providing a signal from 0 to VREF Volt in 256 levels (see further table). Indeed this last possibility is conditioned to the firmware which manages the D/A converter.

VREF:	2.5 V if JP4 is set at	1V/mV
	1.25 V if JP4 is set at	0.5V/mV
	0.625 V if JP4 is set at	0.25 V/mV

- **Main supply change:** referring to the electric diagram of the PSPT board (5802205 or 5802210 x rel.  $\geq 3.00$ ), the terminals of the transformer TR1 (B-white, R-red, G-yellow, V-green) have to be connected as follows:

220 V: R and G  
 110 V: B and G    R and V

- **JP4 (two soldering points) on 5802205 (or 5802210 x rel.  $\geq 3.00$ ) board:** must be close
- **JP12 (three soldering points) on 5802205 (or 5802210 x rel.  $\geq 3.00$ ) board:** the pins 2 and 3 must be in short circuit.

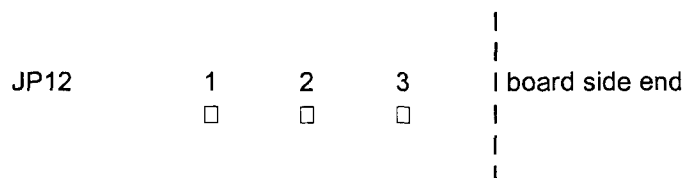

## 4.2 FW "Service setup procedure"

After switch on unit, press "MENU" key, when on display appear:

APPLICATION:  
REST ECG

press "→" key

APPLICATION:  
SETUP

press "START/STOP" key

SETUP MENU:  
SYSTEM SETUP

press "←" key

SETUP MENU:  
FUNCTION

press "START/STOP" key

FUNCTION  
BATTERY CHARGER

press "←" key

FUNCTION  
SERVICE SETUP

press "START/STOP" key

PASSWORD:

pressing "SHIFT" ↑ key press in sequence: "P, D, M, A, M" keys,  
and then have to press "RETURN" ↓ key

SERVICE SETUP:  
HEAD RESISTANCE

press "→" to enter in:

- CLEAR COUNTERS
- BATTERY LIFE CNT
- PRINTER LIFE CNT
- SUPPLY
- STROBE ALARM TST
- MEMORY TEST

Note:

- ⇒ To confirm the choice press "RETURN" ↓ key
- ⇒ To insert new data, is necessary to confirm every data, every time by mean "RETURN" ↓ key
- ⇒ To return to main menu, press some time the "MENU" key

## 5. Troubleshooting Procedures

PROBLEM	POSSIBLE CAUSE	SOLUTION
THE UNIT DOES NOT WORK BY AC	CHECK WALL AC SOCKET	CALL CUSTOMER ELECTRICIAN
	AC CABLE	CHANGE AC CABLE
	AC FUSES	CHANGE AC FUSE
	POWER SUPPLY BOARD	CHANGE POWER SUPPLY BOARD
	TRANSFORMER GROUP	CHANGE TRANSFORMER GROUP
THE UNIT DOES NOT WORK BY BATTERY	BATTERY ELEMENTS	CHANGE BATTERY
	BATTERY FUSE	CHANGE BATTERY FUSE
	BATTERY WIRES/CONNECTOR	CONNECT BATTERY TO THE BOARD
	BATTERY CONDITION	SWITCH OFF/ON UNIT SOME TIMES
THE UNIT DOES NOT WORK	POWER SWITCH	CHANGE POWER SWITCH
	POWER SUPPLY BOARD	CHANGE POWER SUPPLY BOARD
	CPU BOARD	CHANGE CPU BOARD
PRINTER PROBLEM	PAPER SENSOR	CHANGE PRINTER GROUP
	MOTOR DRIVE	CHANGE PRINTER GROUP
	THERMAL HEAD	CHANGE PRINTER GROUP
	PAPER DRIVE	CHANGE POWER SUPPLY BOARD
NO ECG SIGNAL AND/OR "OL" MESSAGE	PATIENT CABLE	CHANGE PATIENT CABLE
	ELECTRODES	CHANGE ELECTRODES
	ECG SELECTOR	CHANGE CPU BOARD
	ECG INPUT CIRCUIT	CHANGE "IN ECG" & "ANALOGIC" BOARDS (HAVE TO CHANGE TOGETHER)
NO WRITE ON PAPER	THERMAL HEAD	CHANGE PRINTER GROUP
PAPER SPEED WRONG	PAPER MEASURES	USE ORIGINAL PAPER
	PAPER SPEED CIRCUIT	CHANGE POWER SUPPLY BOARD



<b>PROBLEM</b>	<b>POSSIBLE CAUSE</b>	<b>SOLUTION</b>
OUT GENERAL CALIBRATION	"IN ECG" & "ANALOGIC" BOARD	PLEASE SEND "IN ECG" & "ANALOGIC" BOARDS TO REMCO
	POWER SUPPLY BOARD	PLEASE SEND POWER SUPPLY BOARD TO REMCO
SOME DOTS ARE MISSING ON PAPER	THERMAL HEAD	CHANGE PRINTER GROUP
	THERMAL HEAD	CHECK POWER SUPPLY BOARD (STROBE/TEMPERATURE ALARM)
	THERMAL HEAD	CHECK MEMORY BOARD (FW ERROR)
	BAD PAPER	USE ORIGINAL PAPER
ERROR MESSAGES	CPU BOARD	SEE ATTACHED ERROR TABLE
	MEMORY BOARD	SEE ATTACHED ERROR TABLE
	CPU BOARD	SEE ATTACHED ERROR TABLE
	BATTERY	SEE ATTACHED ERROR TABLE
LOOSE SETUP	UPU BOARD	CHANGE UPU BOARD (DALLAS ERROR). PLEASE REMAKE SETUP (THERMAL HEAD IMPEDANCE, DATE, TIME, ETC.) SEE SETUP PROCEDURES
	ELECTROSTATIC CHARGES	PLACE PROBLEM. PLEASE CALL REMCO SERVICE DEPT.
SOME KEYS DOES NOT WORK	KEYBOARD LABEL	CHANGE LABEL
	UPU BOARD	CHANGE UPU BOARD
AC NOISE ON ECG TRACES	"IN ECG" & "ANALOGIC" BOARD	CHANGE "IN ECG" & "ANALOGIC" BOARDS (HAVE TO CHANGE TOGETHER)
	POWER SUPPLY BOARD	PROBABLE BAD GROUND CONTACT
DOES NOT WORK THE BATTERY CHARGER	BATTERY	CHANGE BATTERY
	POWER SUPPLY BOARD	CHANGE POWER SUPPLY BOARD
	CPU BOARD	CHANGE CPU BOARD
	MEMORY BOARD	CHANGE MEMORY BOARD
WRONG INTERPRETATION	MEMORY BOARD	CHANGE MEMORY BOARD

## 5.1 Error Codes

E0000	BAD INTERRUPT	Bad interrupt signal generated from CPU, probable sw error
E0001	BAD OPCODE	A wrong command has been read from CPU, probable sw error
E0002	NO APPLICATIONS	No applications. Check the FLASH contents
E0003	BAD FLASH TYPE	FLASH does not answer to the CPU
E0004	RAM MALFUNCTION	Communications RAM error
E0005	CPU RST ERROR	The $\mu$ P '198 does not answer. Probable communication error
E0006	CPU INT ERROR	The $\mu$ P '198 can't work. The INT line from CPU has problems
E0007	CLOCK EXHAUSTED	The DALLAS internal battery is damaged
E0008	CLOCK BAD CHECK	Error in DALLAS data
E0009	BATTERY DAMAGED	Battery damaged. The unit can be used
E0010	BATTERY DAMAGED	Battery damaged. The unit can't be used
E0011	CPU RAM ERROR	Main RAM test error. Change it
E0012	NV RAM ERROR	DALLAS RAM error. Change it
E0013	PARAM ERROR	Error in FLASH data managing.
E0014	PARAMS BAD CHECK	Error in FLASH data. Go on
E0015	CPU MALFUNCTION	The $\mu$ P '198 does not work. Probable software error
E0016	PRINTER ALARM 1	Thermal head strobe alarm
E0017	PRINTER ALARM 2	Thermal head temperature alarm
E0018	BATTERY TEST	Press start/stop key and go on.
E0019	BATTERY OUT	Battery out
E0022	HEAP ERROR	Memory error, bad Flash configuration
E0100 ÷ 0999	DRIVER ERROR	Driver error. Software problem
E1000 ÷ 1099	RUNTIME ERROR	Application error. Software problem

## 6. Technical Features

<b>Leads</b>	12 standard leads
<b>Channels</b>	6
<b>Recording programs</b>	2 automatic programs 1 manual program 1 automatic of arrhythmic recognition 1 automatic for CP/I
<b>Writing system</b>	Thermal head 8 dots/mm
<b>Paper</b>	Thermal z-fold or roll 210 mm x 30 m ( $\pm 5\%$ ) size
<b>Paper speed</b>	6.25 - 12.5 - 25 - 50 mm/s $\pm 5\%$
<b>Sensibility</b>	5 - 10 - 20 mm/mV
<b>Display LCD</b>	Alphanumeric to visualize alarm and operative messages
<b>Linear phase digital filters</b>	Low pass: M1 40 Hz (-3dB); M2 30Hz (-3dB); M3 25 Hz (-3dB) HUMM filter to reject the main supply noise (50-60 Hz) High pass (drift filter): 0.5 Hz
<b>Auxiliary connections</b>	Bi-directional RS232 port 2 analog inputs with sensitivity 0.5 V/mV 3 channels of analog out with sensitivity 0.5 V/mV
<b>Frequency response</b>	0.05 + 150 Hz (-3 dB)
<b>Time constant</b>	>3.2 sec.
<b>Noise rejecting</b>	>110 dB
<b>Input impedance</b>	>100 M $\Omega$ at all the leads
<b>Leakage current</b>	<10 $\mu$ A
<b>Defibrillator discharge protection</b>	As per IEC 62-76 rules
<b>Class and type (as per IEC 601-1)</b>	Power supply Class I patient input type CF
<b>Power supply</b>	115 V $\pm 10\%$ 60 Hz / 230 V $\pm 10\%$ 50 Hz and Internal rechargeable battery with auto switch-OFF
<b>Fuses</b>	2 fuses type T250 mA, 5x20 mm (230 V) 2 fuses type T500 mA, 5x20 mm (115 V)
<b>Max power absorption</b>	60 VA max
<b>Autotest</b>	Functional check and printer test
<b>Dimensions</b>	340 X 425 X 110 mm
<b>Weight</b>	5.8 Kg.
<b>Operating Temperature</b>	From +10° to 40° C Relative humidity from 25 to 75% Atmospheric pressure from 700 to 1060 mbar
<b>Storing temperature</b>	From -30° to +50° C Relative humidity from 25 to 95% Atmospheric pressure from 700 to 1060 mbar

## 7. Spare parts list

2811060	_____	Switch
2811111	_____	ECG input socket
2820057	_____	Printer group
2990154	_____	Upper case group
2990155	_____	Lower case
5400361	_____	24 V 50 VA transformer
5802192	_____	LCD display
5802200	_____	ECG input board
5802201	_____	Analog board
5802203	_____	CPU board
5802204	_____	Memory board
5802205	_____	Power supply/printer board
5802207	_____	Printer adapter board
5802208	_____	User peripheral board
5802210	_____	Power supply/printer board (x rel. $\geq 3.00$ )
5802211	_____	Printer adapter board (x rel. $\geq 3.00$ )
7741715	_____	Battery

## 8. Electric and assembling diagrams

General block diagram

ECG input board diagram \_\_\_\_\_ code 5802200

ANLG board diagram \_\_\_\_\_ code 5802201

CU board diagram \_\_\_\_\_ code 5802203

Memory board diagram \_\_\_\_\_ code 5802204

PSPT board diagram \_\_\_\_\_ code 5802205

PSPT board diagram \_\_\_\_\_ code 5802210 (**x rel.  $\geq 3.00$** )

Printer adapter diagram \_\_\_\_\_ code 5802207

Printer adapter diagram \_\_\_\_\_ code 5802211 (**x rel.  $\geq 3.00$** )

RSAIO board diagram \_\_\_\_\_ code 5802198

UPU board diagram \_\_\_\_\_ code 5802208



REMCO  
ITALIA S.p.A.

CARDIOLINE™

APPROVATO Data. 20/11/96 Firma: *[Signature]*

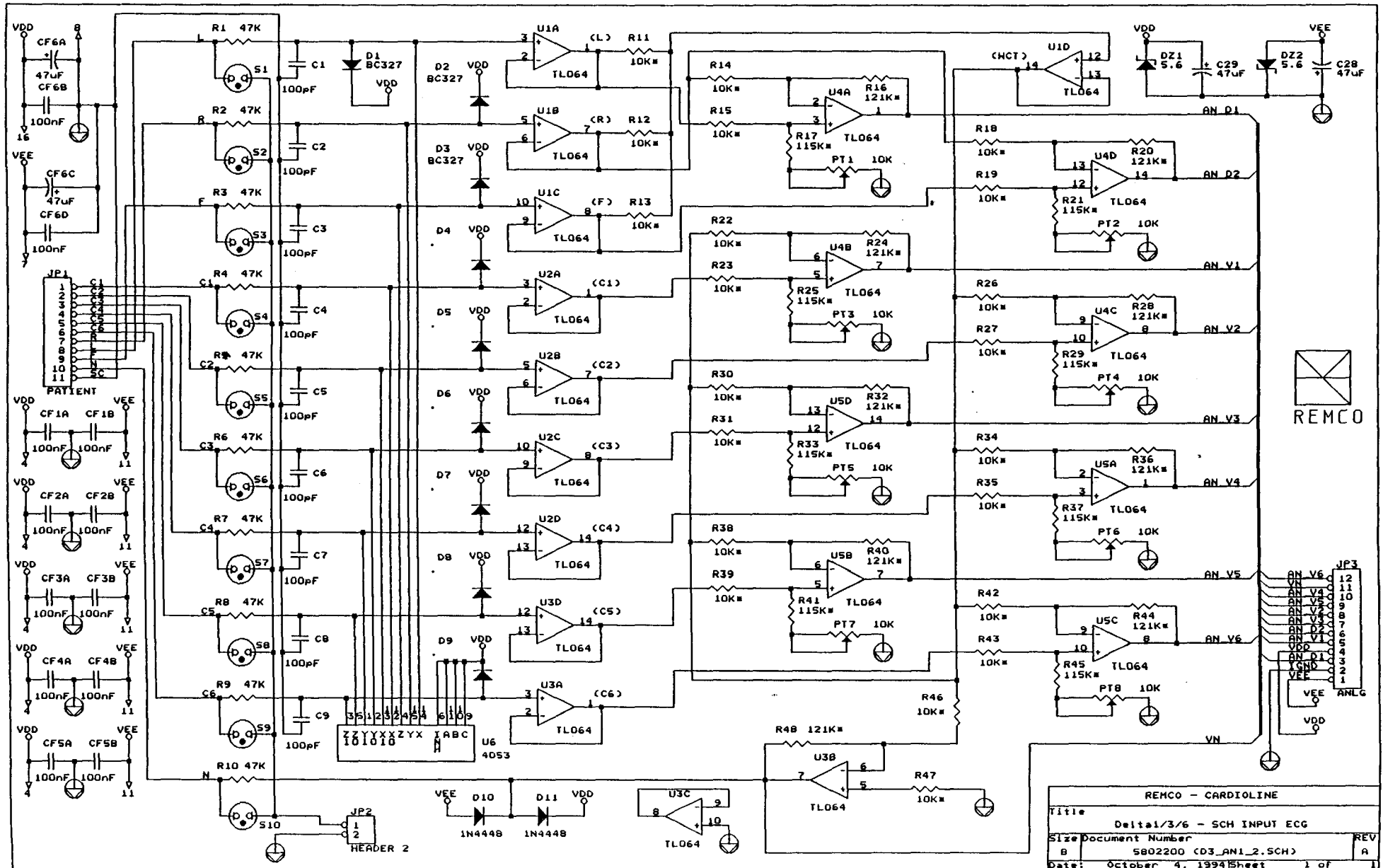

REMCO - CARDIOLINE		
Title	Delta1/3/6 - SCH INPUT ECG	
Size Document Number	B	5802200 (D3_AN1_2.SCH)
REV	A	
Date:	October 4, 1994	Sheet 1 of 1

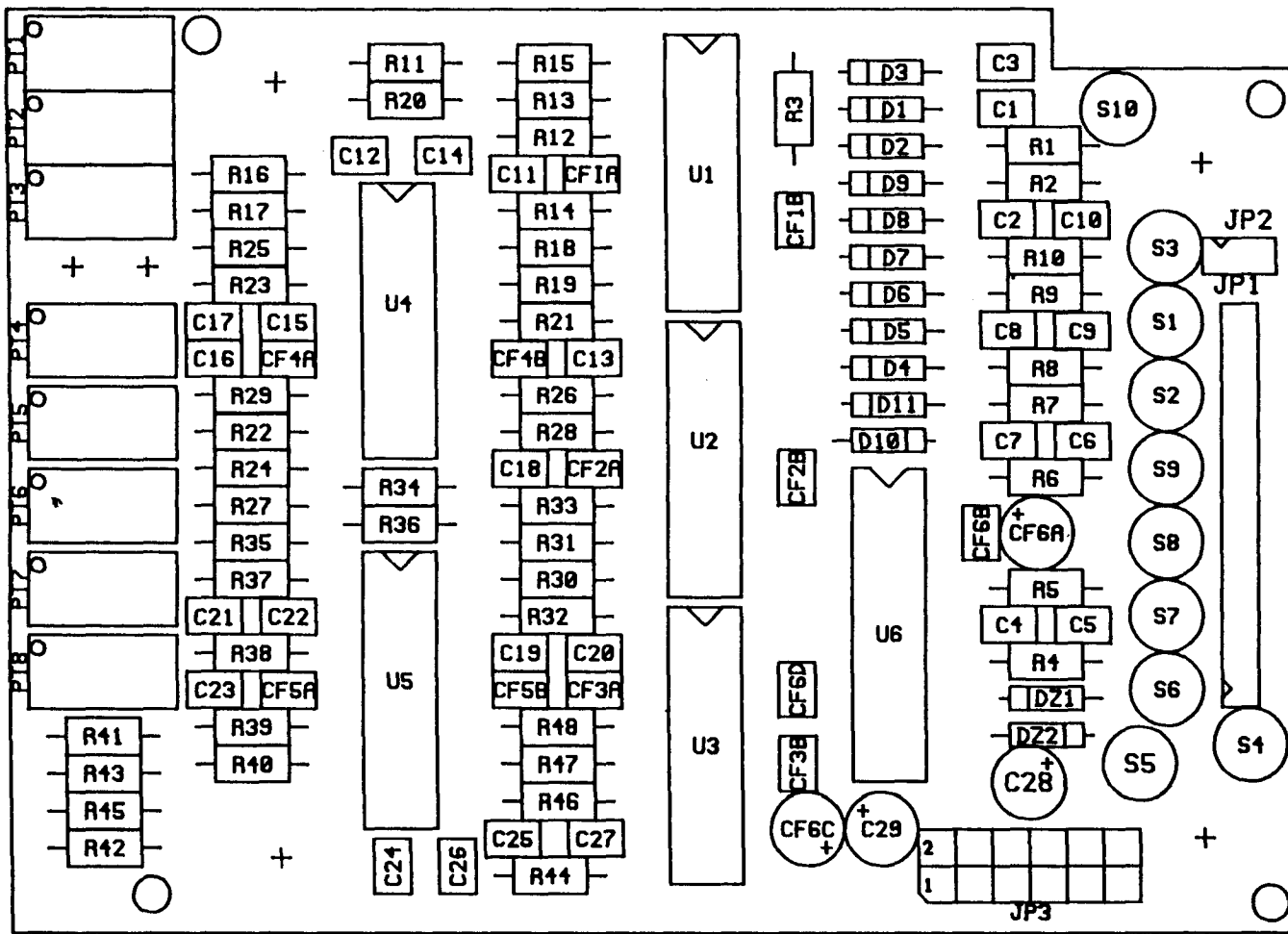

DATA 10-10-93  
 N.DIS. 2013990

REMO  
 ITALIA S.P.A.  
 APPROVATO Data 21/11/86 Firma *SL*



REMCO  
ITALIA S.p.A.

CARDIOLINE®

APPROVATO Data. 21/11/1986 Firma: *[Signature]*

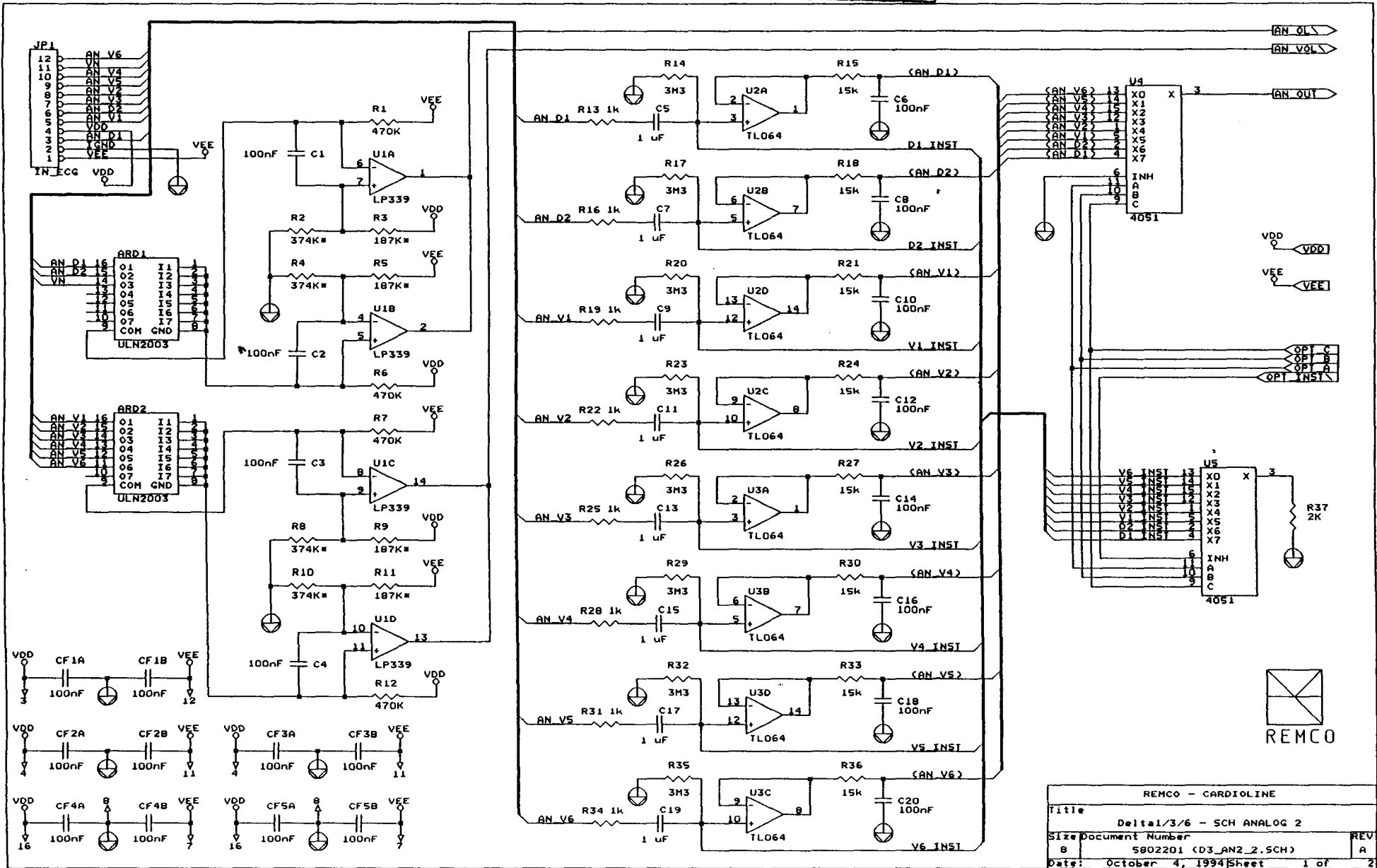

REMCO - CARDIOLINE		
Title	Delta1/3/6 - SCH ANALOG 2	
Size Document Number	B 5802201 (D3_AN2_2.SCH)	
Date:	October 4, 1994	Sheet 1 of 2

REMCO  
ITALIA S.p.A.

CARDIOLINE®

APPROVATO Data 21/11/86 Firma: *[Signature]*

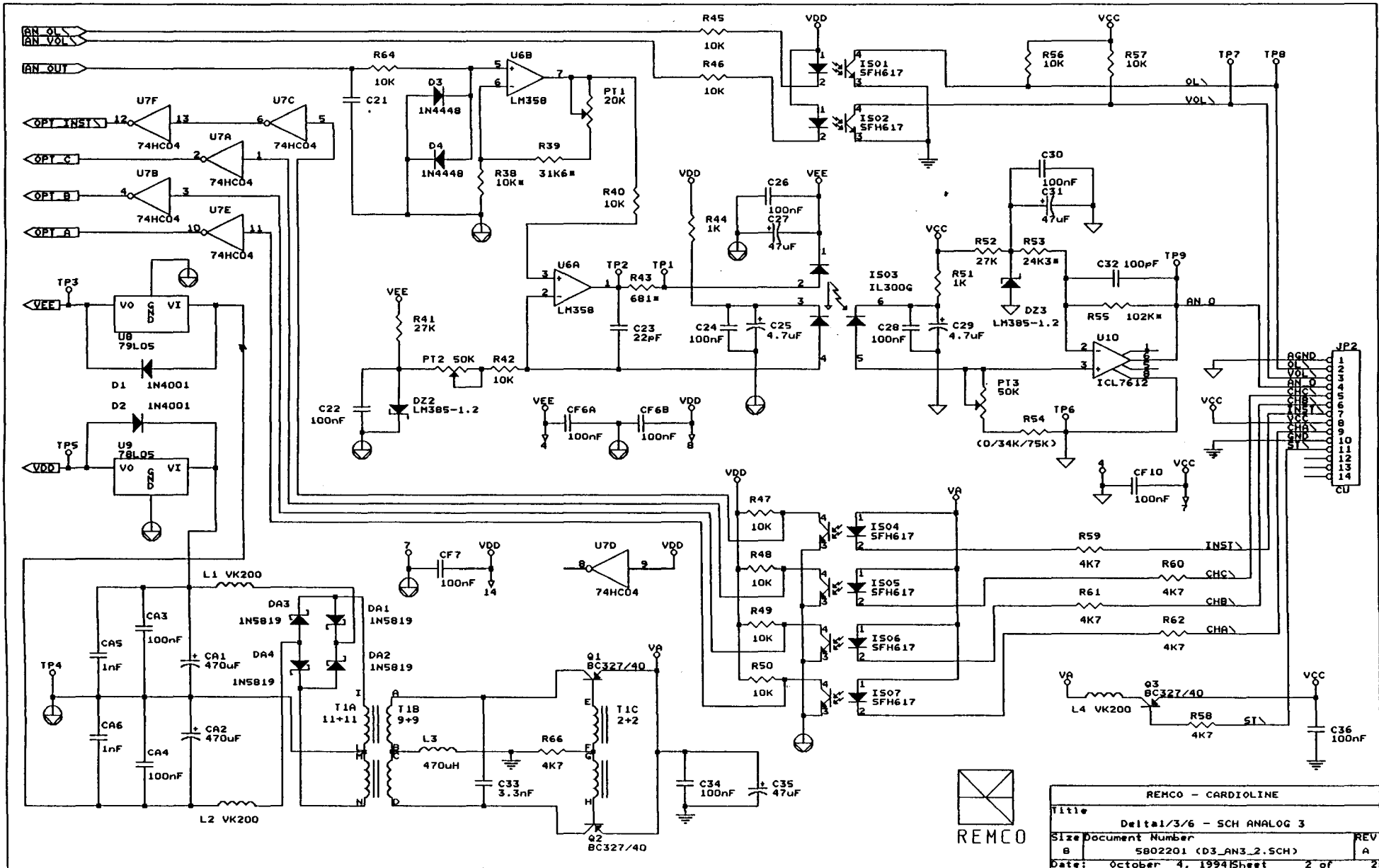

REMCO - CARDIOLINE	
Title	Delta1/3/6 - SCH ANALOG 3
Size Document Number	B
	5802201 (D3_AN3_2.SCH)
Date:	October 4, 1994 Sheet 2 of 2

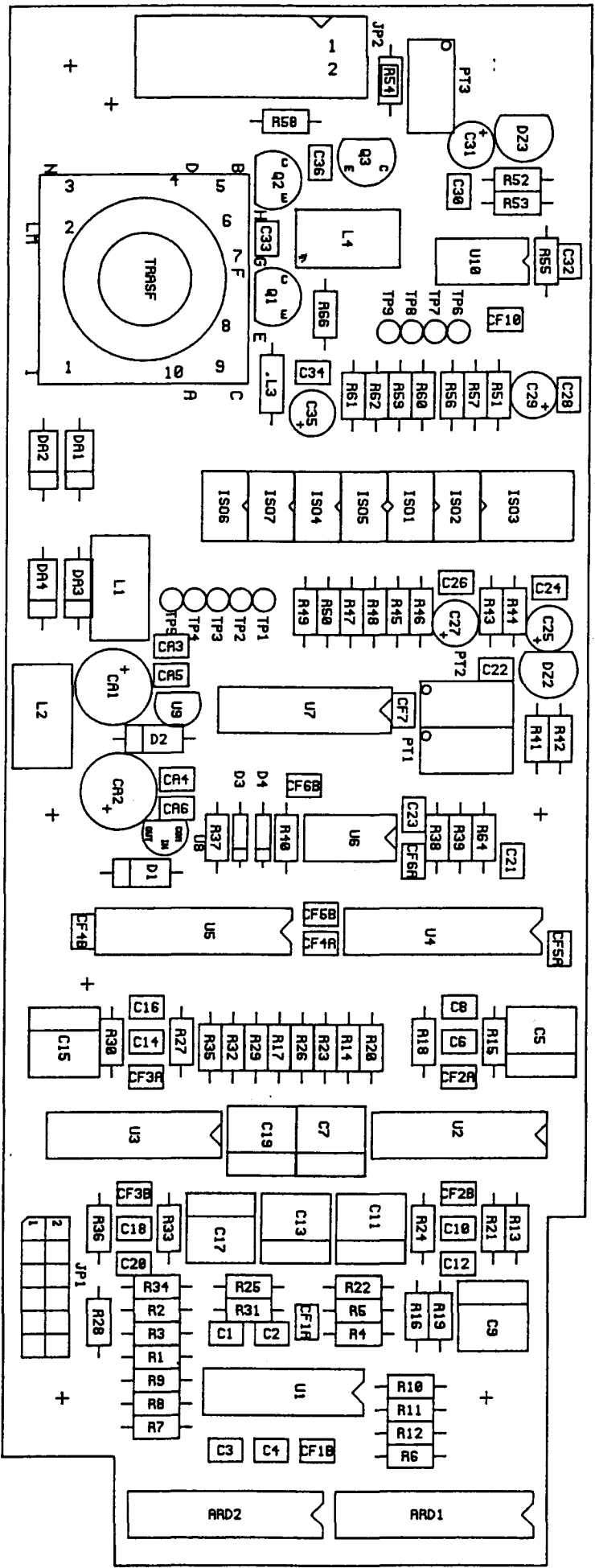

DATA 19-11-93  
 N.DIS. 2013993

**REMCO**  
 ITALIA S.p.A.  
 APPROVATO Data 21/11/86 Firma: *[Signature]*  
**CARDIOLINE**

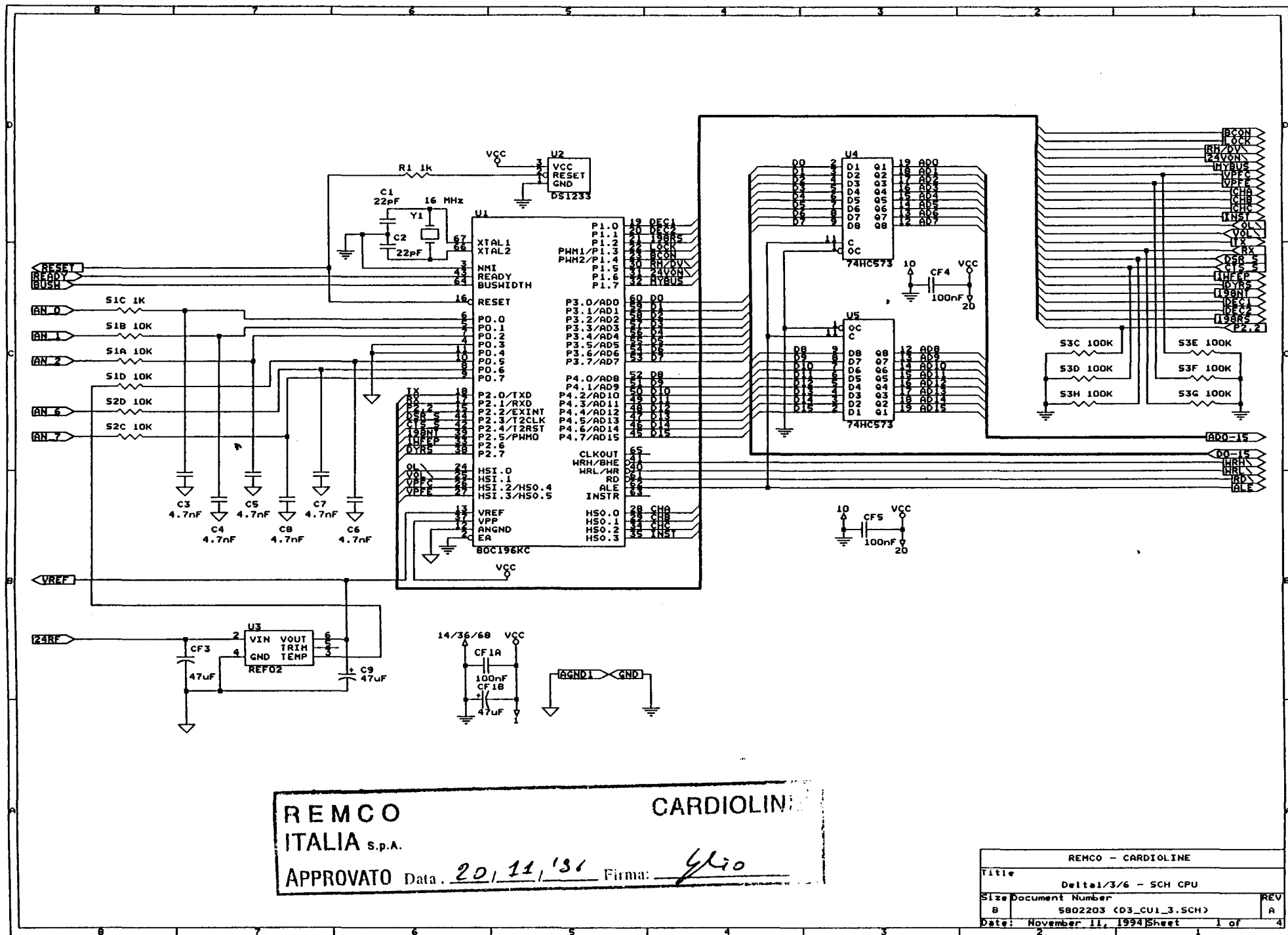

REMCO ITALIA S.p.A. APPROVATO Data. 20/11/86 Firma: *GLio* CARDIOLINE

REMCO - CARDIOLINE	
Title	Delta1/3/6 - SCH CPU
Size Document Number	5802203 (D3_CU1_3.SCH)
B	REV A
Date: November 11, 1994	Sheet 1 of 4

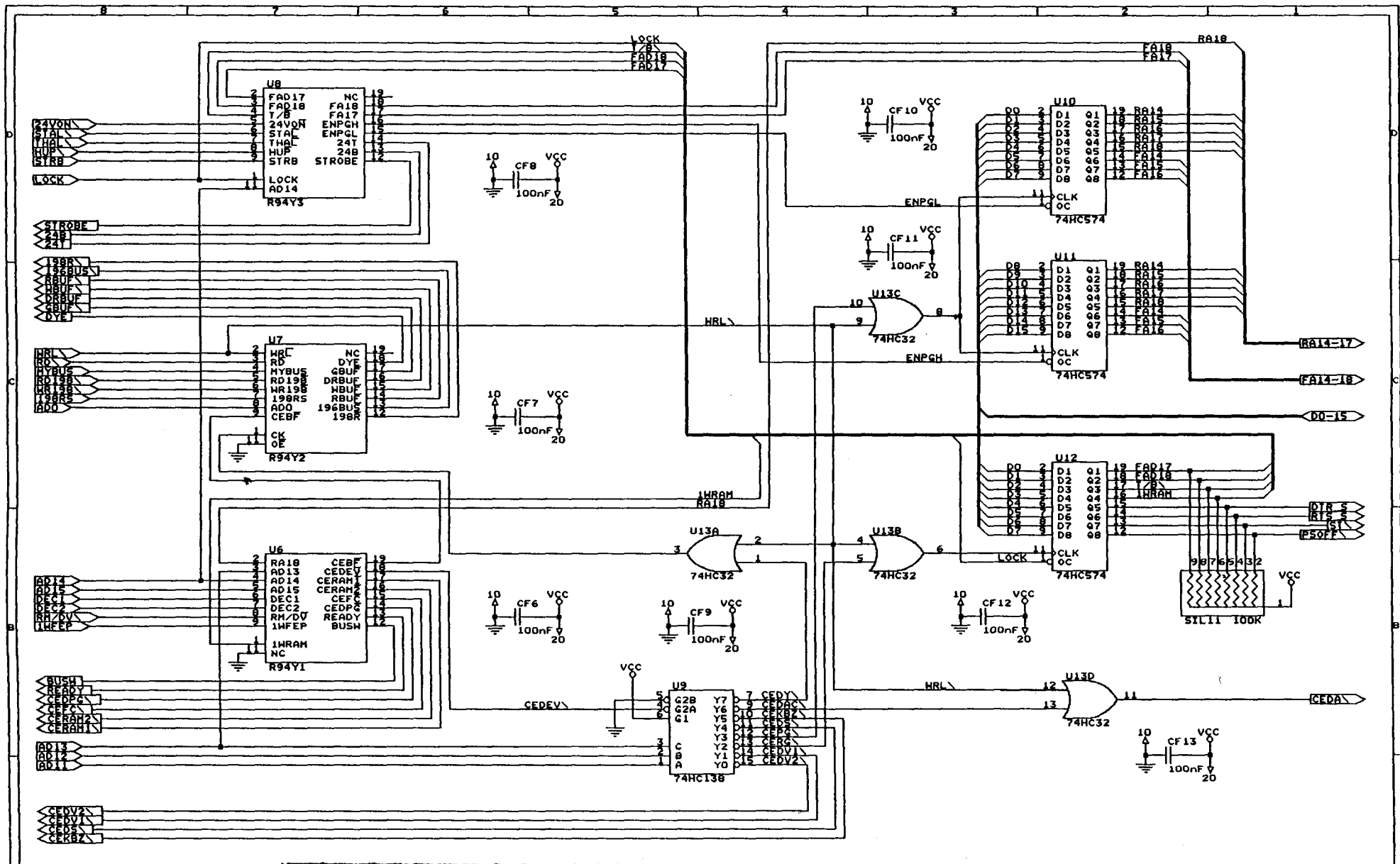

**REMCO**  
**ITALIA** s.p.a.  
 APPROVATO Data. 20/11/96 Firma: GL

**CARDIOLINE**

REMCO - CARDIOLINE		
Title	DELTA1/3/6 - SCH CPU	
Size Document Number	5802203 (D3_CU2_3.SCH)	
B	REV	A
Date: November 11, 1994	Sheet	2 of 4

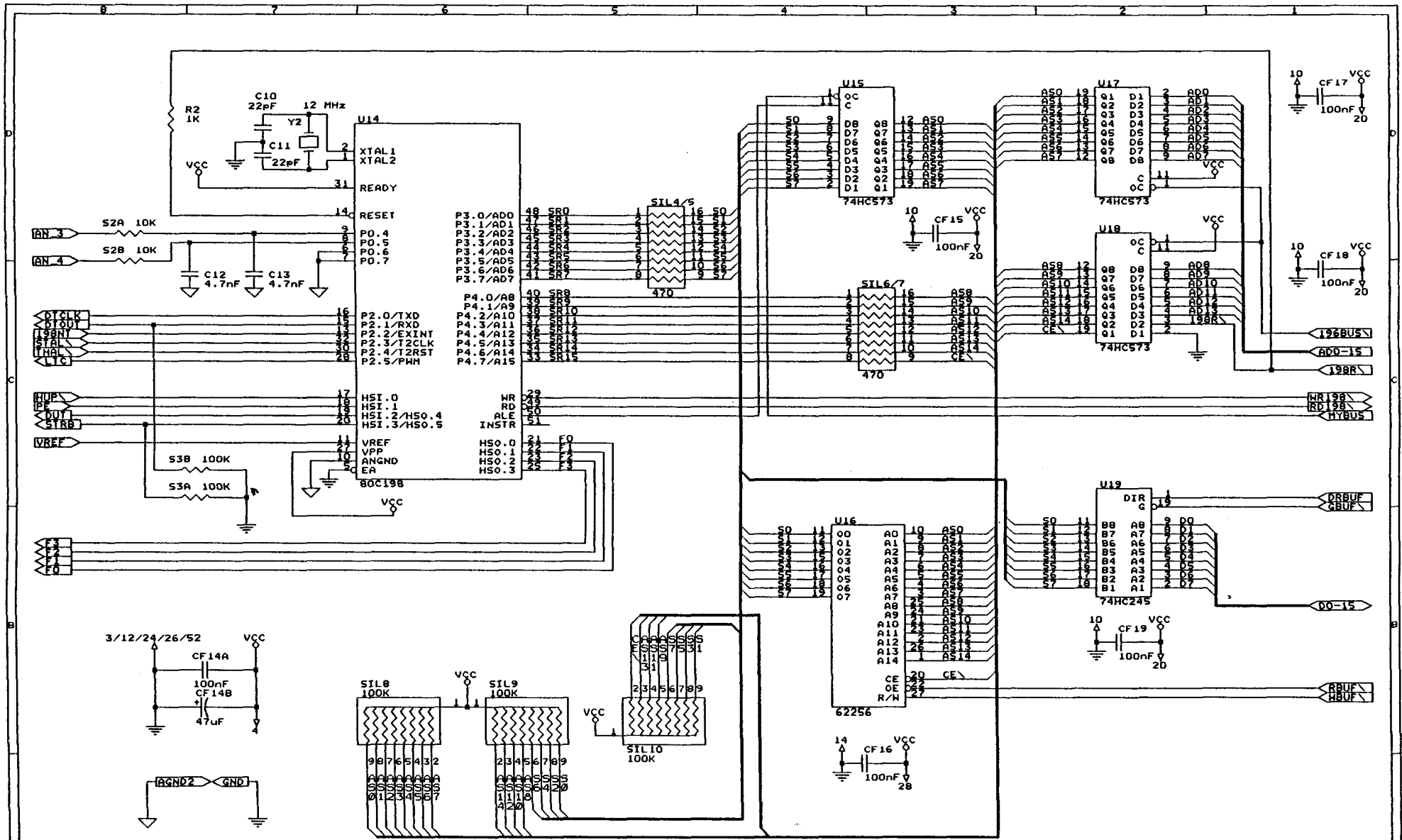

**REMCO**  
**ITALIA S.p.A.**  
 APPROVATO Data: 20/11/96 Firma: GL

**CARDIOLINE<sup>®</sup>**

REMCO - CARDIOLINE	
Title	DELTA1/3/6 - SCH CPU
Size	Document Number
B	5802203 (D3_CU3_3.SCH)
Date:	November 11, 1994 Sheet 3 of 4
REV	A



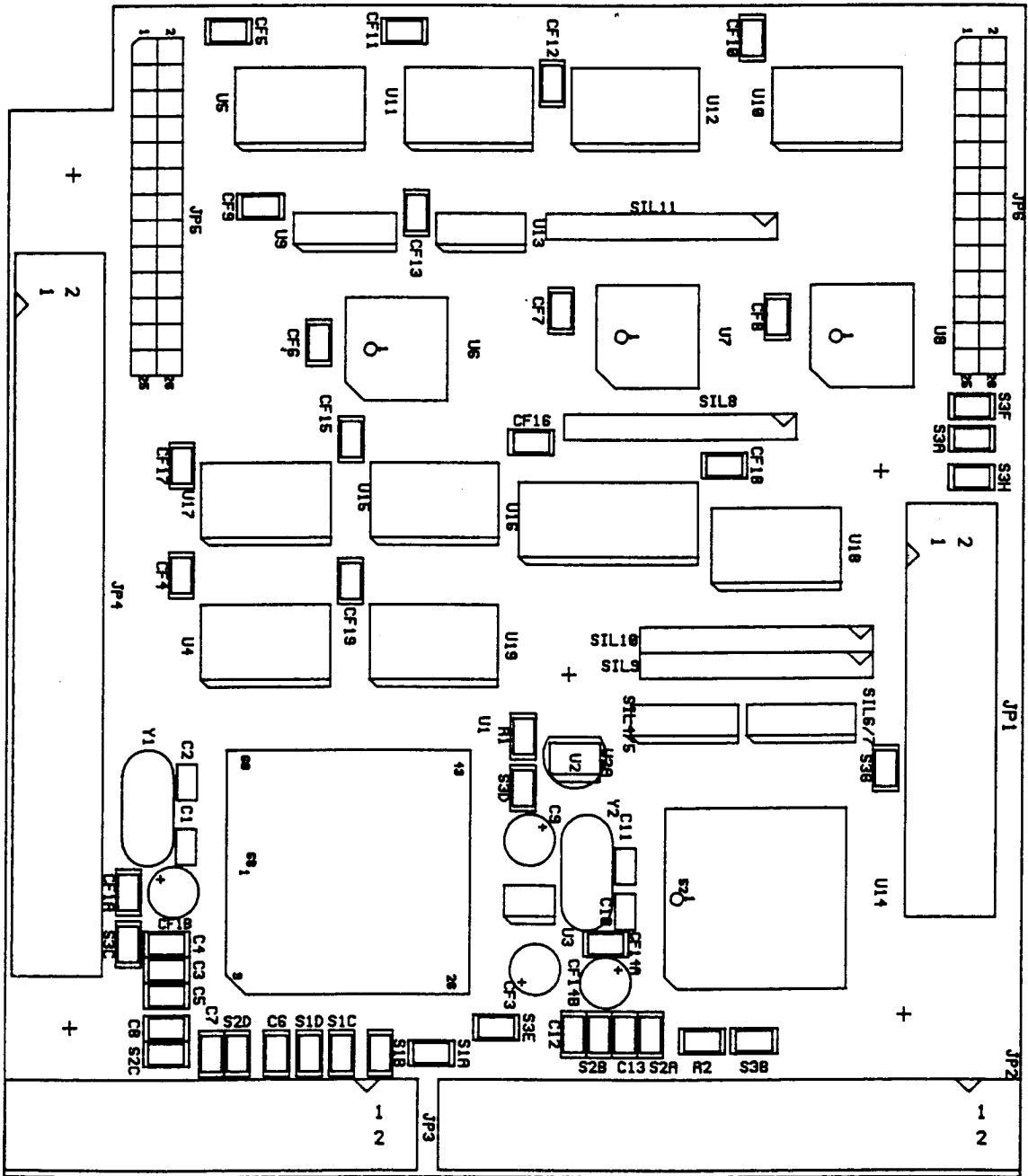

DATR 13-6-94  
N.DIS. 5802203



REMCO  
ITALIA S.p.A.  
APPROVATO Data. 21 / 11 / 96 Firma: GL CARDIOLINE®





REMCO  
ITALIA s.p.a.

CARDIOLINE®

APPROVATO Data. 21 / 11 / '86 Firma: Glio

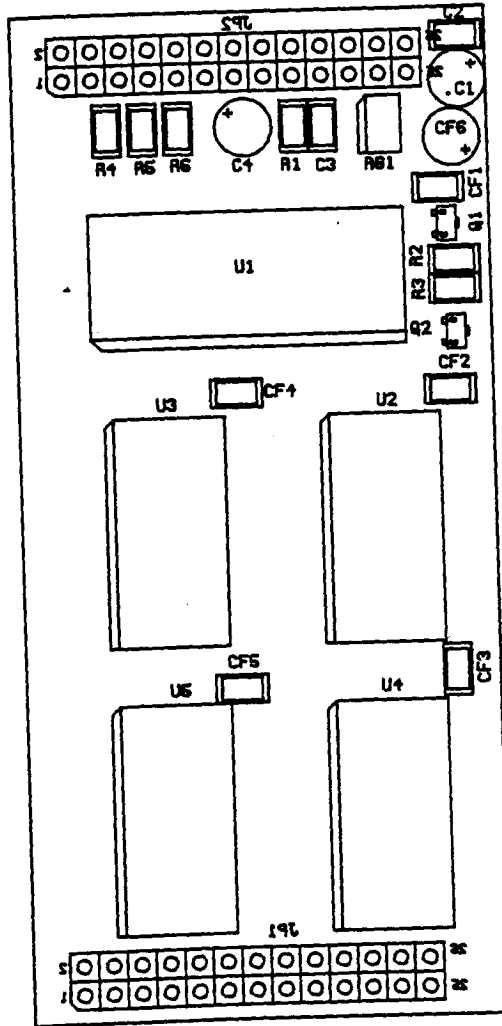

DATA 21-3-84  
N.DIS. 2813996

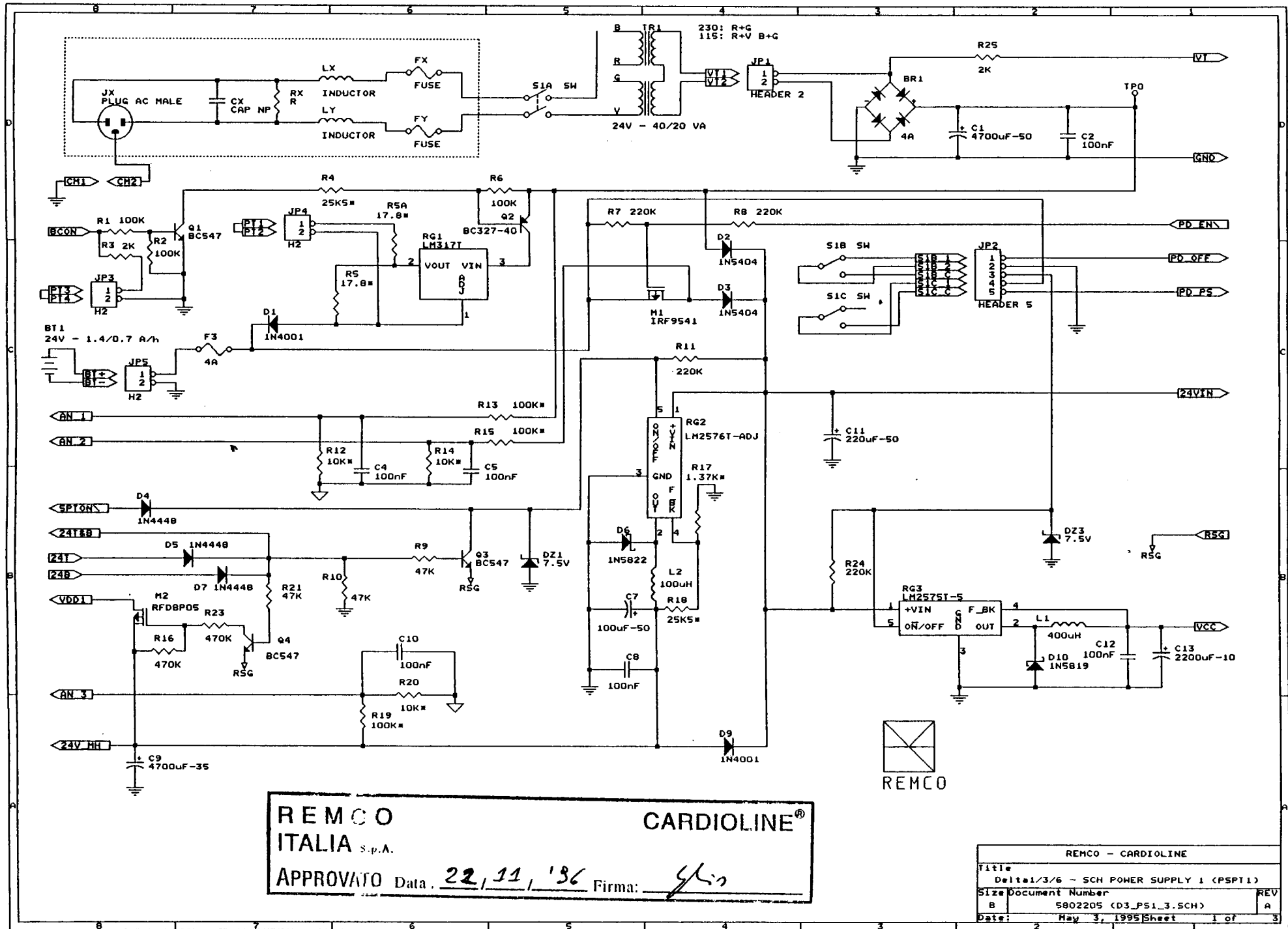

**REMCO**  
 ITALIA S.p.A.  
 APPROVATO Data 22/11/86 Firma: [Signature]

REMCO - CARDIOLINE	
Title	Delta1/3/6 - SCH POWER SUPPLY 1 (PSPT1)
Size	Document Number
B	5802205 (D3_PS1_3.SCH)
Date:	May 3, 1995 Sheet 1 of 3
REV	A

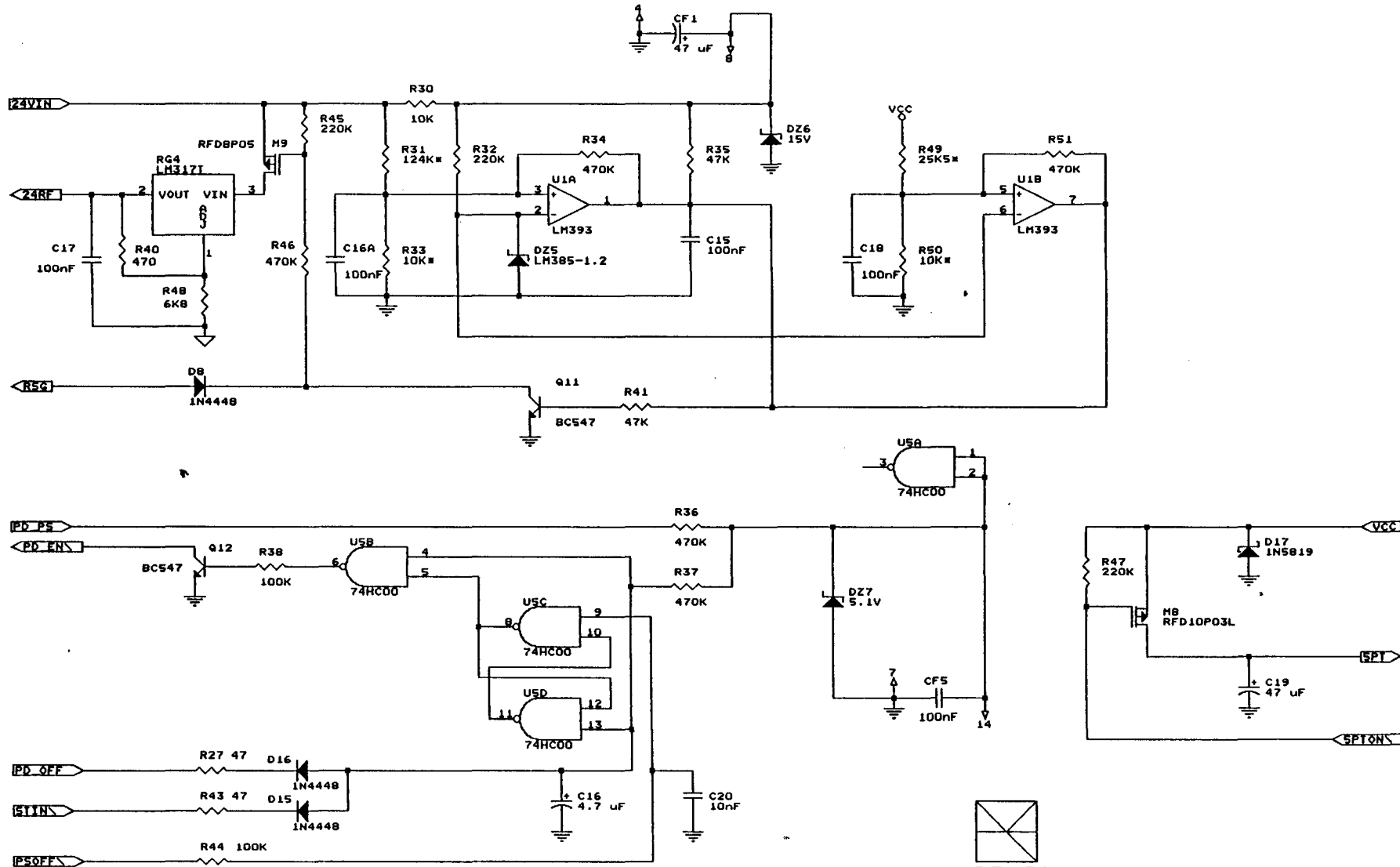

**REMCO**  
**ITALIA** s.p.a.  
 APPROVATO Data: 22 / 21 / '96 Firma: Slis

REMCO - CARDIOLINE	
Title Delta1/3/6 - SCH POWER SUPPLY 2 (PSPT2)	
Size Document Number B 5802205 (D3_PS2_3.SCH)	
Date:	May 3, 1995 Sheet 2 of 3

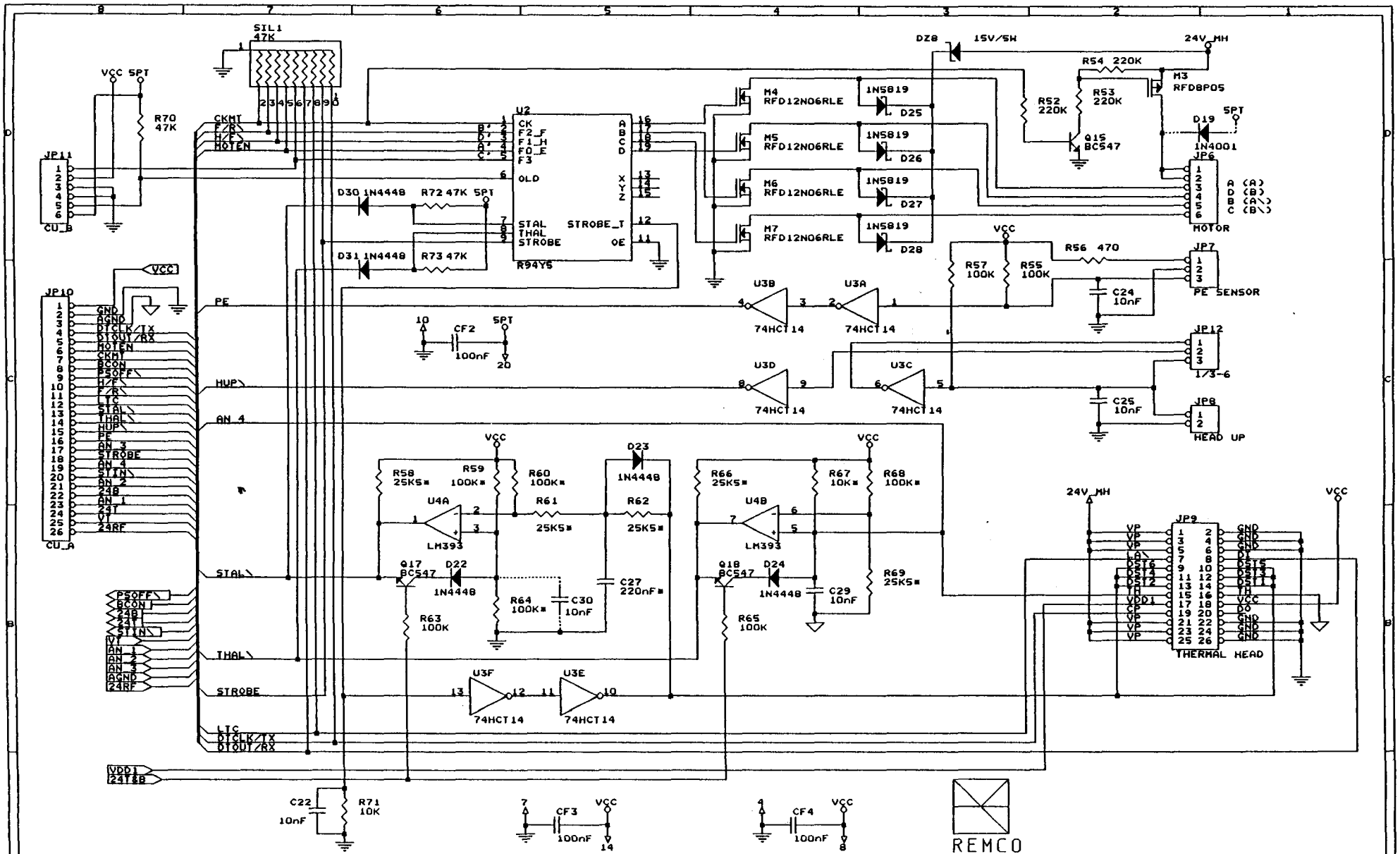

**REMCO**  
 ITALIA S.p.A.  
 APPROVATO Data: 22/11/86 Firma: Gl's

**CARDIOLINE®**

REMCO - CARDIOLINE	
Title	Deltal/3/6 - SCH PRINTER ADAPTER (PSPT3)
Size Document Number	B 5802205 (D3_PTR_3.SCH)
Date:	May 3, 1995 Sheet 3 of 3

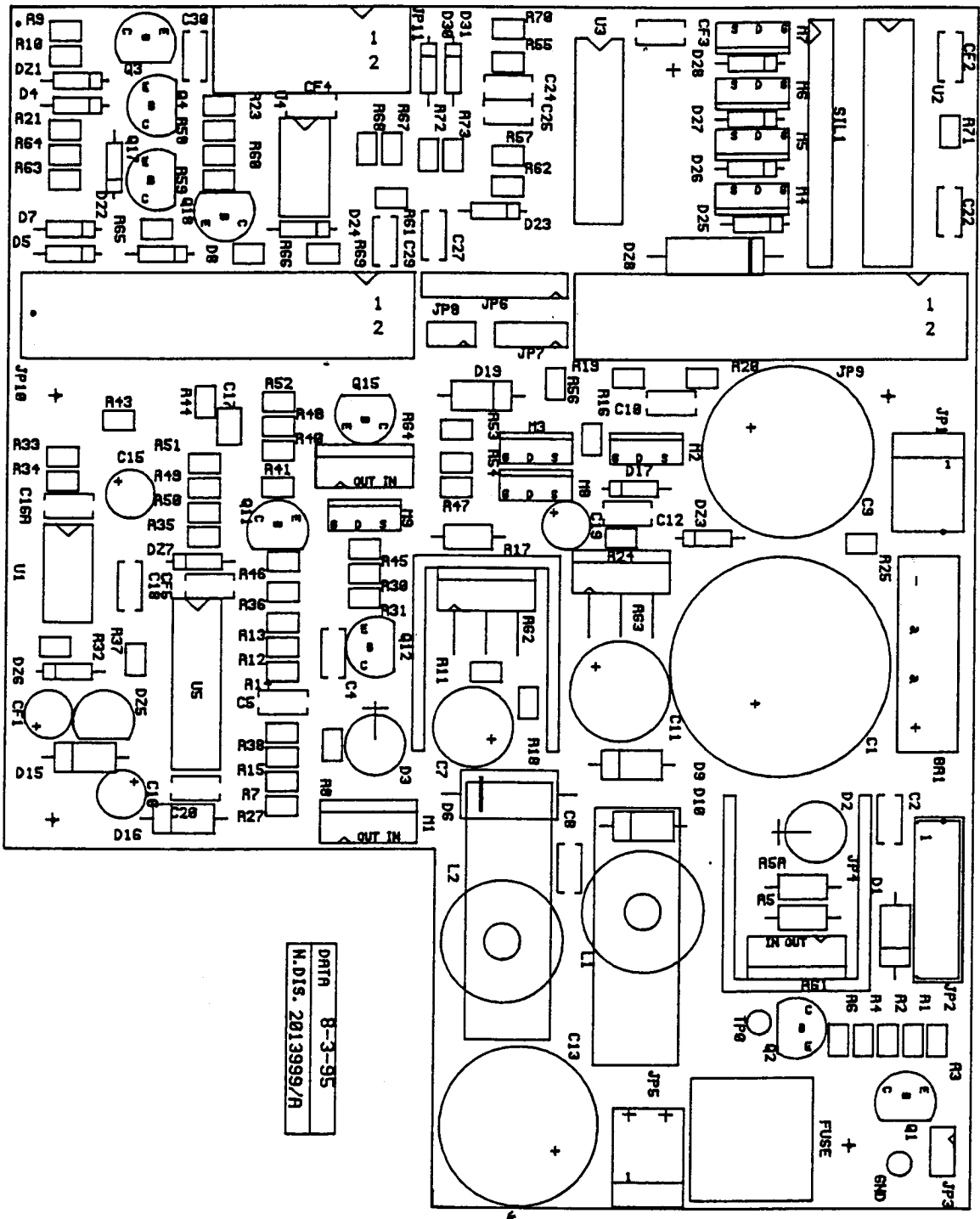

DATA 8-3-95  
 N.DIS. 2013999/H

REMCO  
 ITALIA S.p.A.  
 APPROVATO DATA 22/11/96 Firma: *gl*

CARDIOLINE®



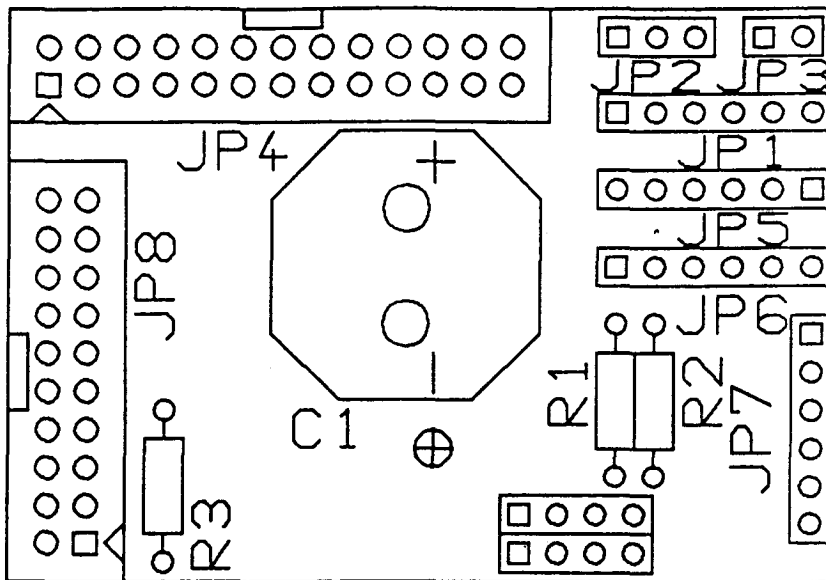

REMCO  
 ITALIA S.p.A.  
 APPROVATO Date: 22 / 11 / '86 Firma: *glio* CARDIOLINE®

2014001  
 5802207





REMCO

ITALIA S.p.A.

CARDIOLINE®

APPROVATO Data 22/11/96 Firma: gl'n

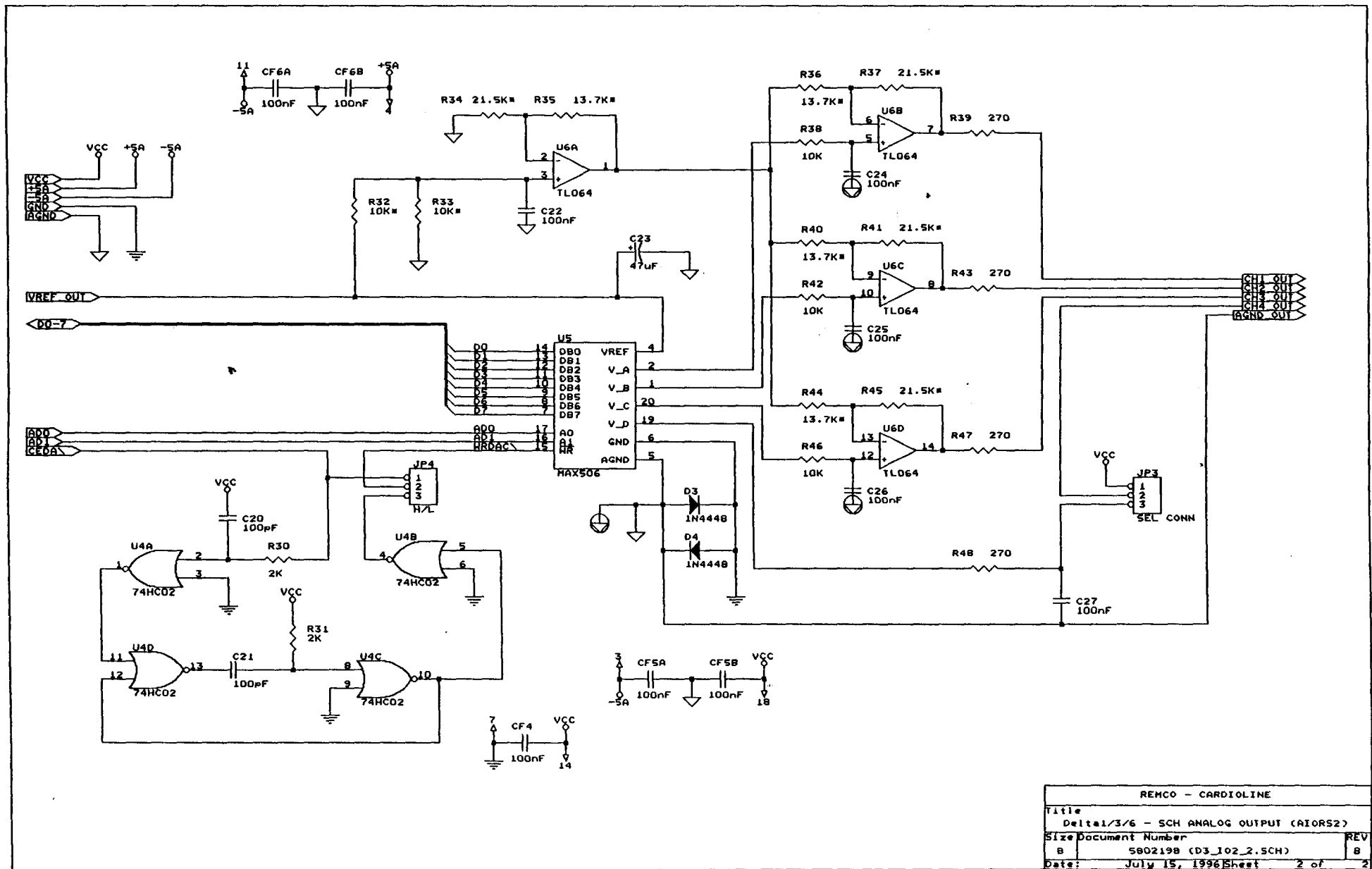

REMCO - CARDIOLINE		
Title	Delta1/3/6 - SCH ANALOG OUTPUT (AIORS2)	
Size	Document Number	REV
B	5802198 (D3_102_2.SCH)	B
Date:	July 15, 1996	Sheet 2 of 2

RITMO O  
 IT/MA  
 APPROVED FOR: 22/11/88 FROM: SL  
 CARDIOLINE®

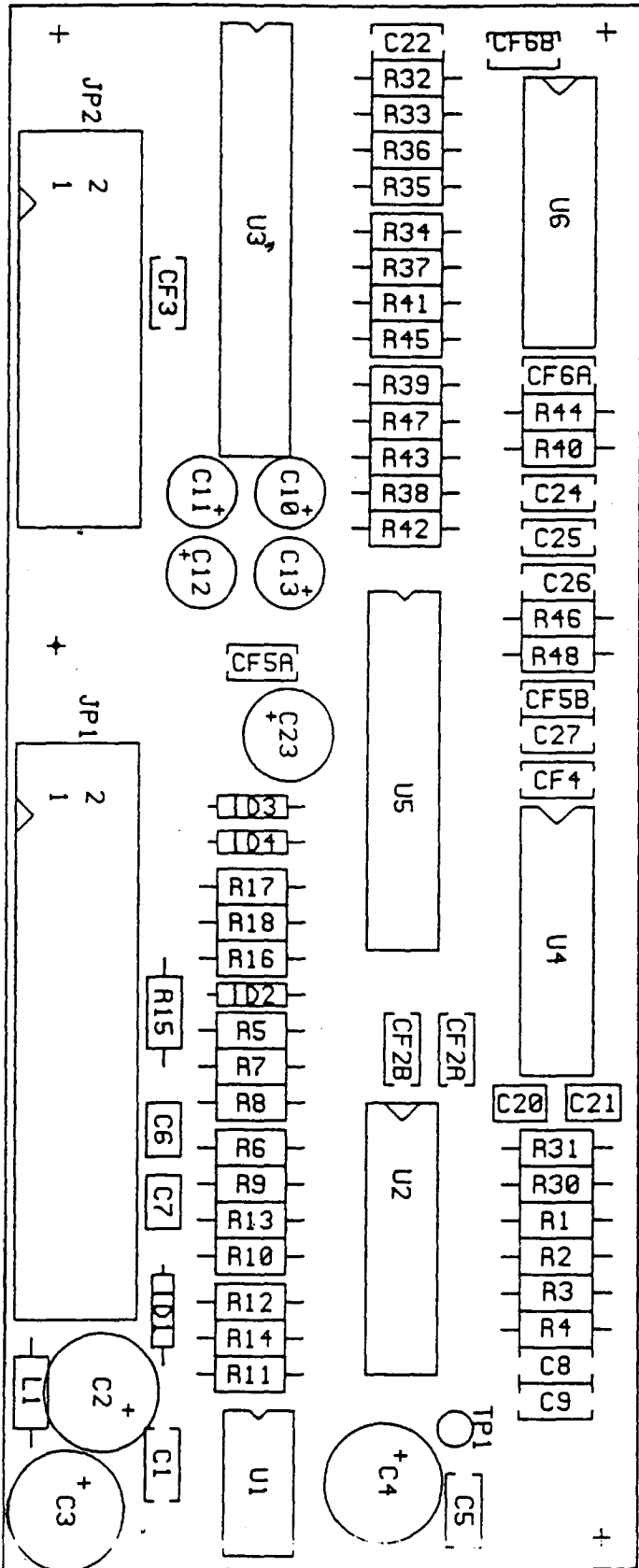

DATA 2-5-93  
 N.DIS. 201.3981

REMCO  
ITALIA S.p.A.

CARDIOLINE®

APPROVATO Data. 21/11/96 Firma: *glv*

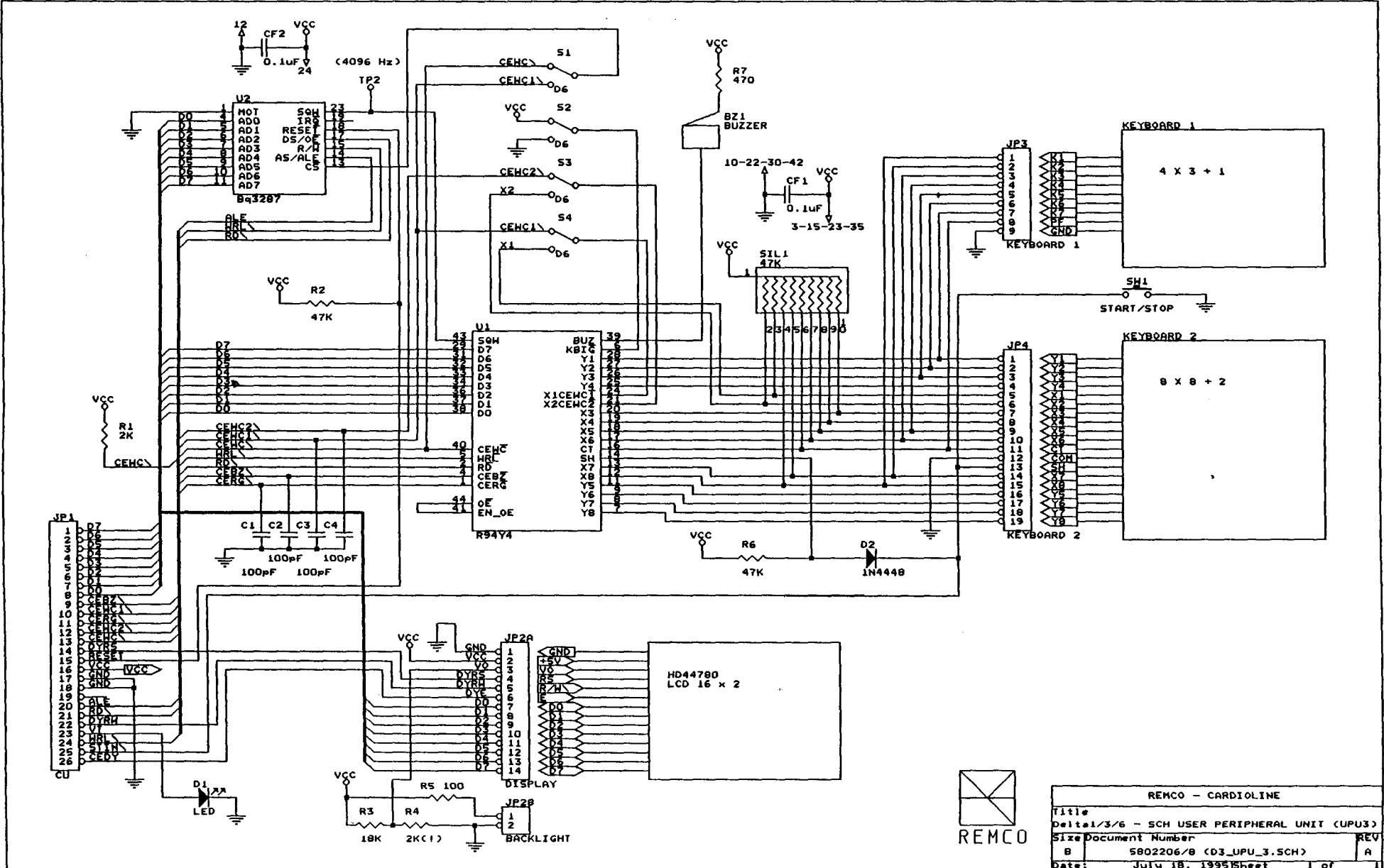

REMCO - CARDIOLINE	
Title	Delta1/3/6 - SCH USER PERIPHERAL UNIT (UPU3)
Size	Document Number
B	5802206/8 (D3_UPU_3.SCH)
Date:	July 18, 1995 Sheet 1 of 1

RE MCO  
ITALIA s.p.a.

CARDIOLINE

APPROVATO Data 21/11/86 Firma: *Lo*

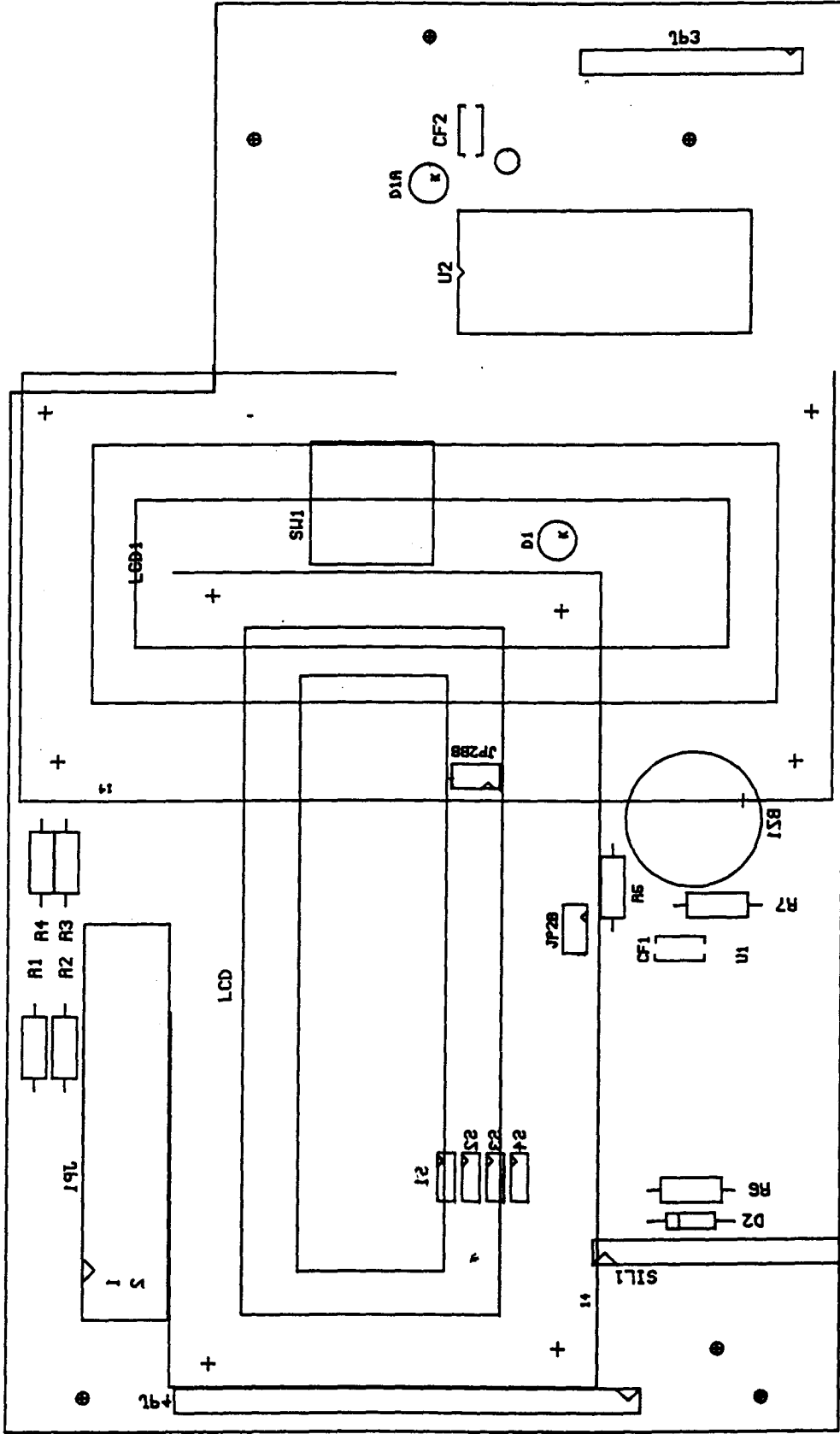

DATA 25-10-94

N.DIS. 2014000

All rights reserved.

No parts of this publication may be reproduced, stored in a retrieval system, or transmitted in any form or by any means, mechanical, photocopying, recording, or otherwise, without the prior written permission of the editor "REMCO ITALIA S.p.A." S. Pedrino di Vignate (MI), ITALY.